

EMPIRICAL DESIGN OF CONCRETE MASONRY WALLS

Keywords: allowable stress, anchorage, bonding, building codes, empirical design, height/thickness ratio, intersecting walls, lateral support, nonbearing wall, parapet, partition walls, shear wall, unreinforced concrete masonry, vertical loads, wall ties

INTRODUCTION

Empirical design is a procedure of proportioning and sizing unreinforced masonry elements based on known historical performance for a given application. Empirical provisions preceded the development of engineered masonry design, and can be traced back several centuries. This approach to design is based on historical experience in lieu of analytical methods. It has proven to be an expedient design method for typical loadbearing structures subjected to relatively small wind loads and located in areas of low seismic risk. Empirical design has also been used extensively for the design of exterior curtain walls and interior partitions.

Using empirical design, vertical and lateral load resistance is governed by prescriptive criteria which include wall height to thickness ratios, shear wall length and spacing, minimum wall thickness, maximum building height, and other criteria, which have proven to be effective through years of experience.

This TEK is based on the provisions of Section 2109 of the *International Building Code* (IBC) (ref. 1). These empirical design requirements do not apply to other design methods such as allowable stress or limit states design. For empirical design of foundation walls, see TEK 15-1B, *Allowable Stress Design of Concrete Masonry Foundation Walls* (ref. 2)

APPLICABILITY OF EMPIRICAL DESIGN

The IBC allows elements of masonry structures to be designed by empirical methods when assigned to Seismic Design Category (SDC) A, B or C, subject to additional restrictions described below. When empirically designed elements are part of the seismic lateral force resisting system, however, their use is limited to SDC A.

Empirical design has primarily been used with masonry laid in running bond. When laid in stack bond, the IBC requires a minimum amount of horizontal reinforcement (0.003 times

Table 1—2006 IBC Empirical Design Limitations Based on Building Height and Basic Wind Speed^A

Masonry wall type:	Building height, <i>h</i> , ft (m)	Basic wind speed, <i>w</i> , mph (m/s)			
		<i>w</i> ≤ 90 (<i>w</i> ≤ 40)	90 < <i>w</i> ≤ 100 (40 < <i>w</i> ≤ 45)	100 < <i>w</i> ≤ 110 (45 < <i>w</i> ≤ 49)	110 < <i>w</i> (49 < <i>w</i>)
Part of the lateral force-resisting system	$h \leq 35$ (11)	Allowed			Not allowed
Interior, not part of the lateral force-resisting system, in buildings other than enclosed ^A	$h > 180$ (55)	Not allowed			
	60 (18) < $h \leq 180$ (55)	Allowed	Not allowed		
	35 (11) < $h \leq 60$ (18)	Allowed		Not allowed	
Exterior, not part of the lateral force-resisting system	$h \leq 35$ (11)	Allowed			Not allowed
	$h > 180$ (55)	Not allowed			
	60 (18) < $h \leq 180$ (55)	Allowed	Not allowed		
Exterior	35 (11) < $h \leq 60$ (18)	Allowed		Not allowed	
	$h \leq 35$ (11)	Allowed			Not allowed

^A Per *Minimum Design Loads for Buildings and Other Structures*, ASCE 7 (ref. 4).

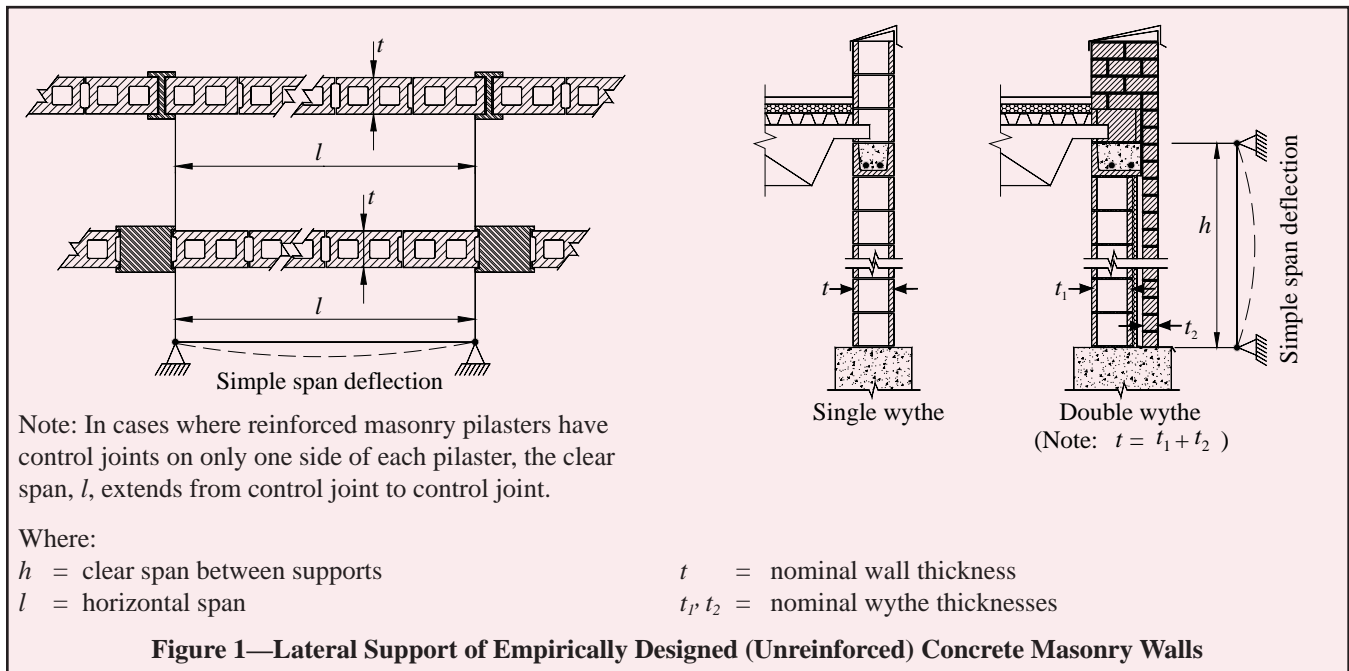

Table 2—Wall Lateral Support Requirements (ref. 1)

Construction (unreinforced)	Maximum wall length-to-thickness or height-to-thickness ratio ^A
Bearing walls	
Solid units or solid grouted	20
All others	18
Nonbearing walls	
Exterior	18
Interior	36
Cantilever walls^B	
Solid	6
Hollow	4
Parapets (8-in. (203-mm) thick min.) ^B	3

^A Ratios are determined using nominal dimensions. For multiwythe walls where wythes are bonded by masonry headers, the thickness is the nominal wall thickness. When multiwythe walls are bonded by metal wall ties, the thickness is taken as the sum of the wythe thicknesses. Note that Reference 6 includes modified requirements for walls with openings.

^B The ratios are maximum height-to-thickness ratios and do not limit wall length.

Table 3—Maximum Unreinforced Wall Spans, ft (m)^A

Wall thickness, in. (mm)	6 (152)	8 (203)	10 (254)	12 (305)
Bearing walls				
Solid or solid grouted	10 (3.0) ^B	13.3 (4.1)	16.6 (5.1)	20 (6.1)
All other	9 (2.7) ^B	12 (3.7)	15 (4.5)	18 (5.5)
Nonbearing walls				
Exterior	9 (2.7)	12 (3.7)	15 (4.5)	18 (5.5)
Interior	18 (5.5)	24 (7.3)	30 (9.1)	36 (11)
Cantilever Walls^C				
Solid	3 (0.9)	4 (1.2)	5 (1.5)	6 (1.8)
Hollow	2 (0.6)	2.6 (0.8)	3.3 (1.0)	4 (1.2)
Parapets ^C	1.5 (0.5)	2 (0.6)	2.5 (0.8)	3 (0.9)

^A Note that Ref. 6 includes modified requirements for walls with openings.

^B Unreinforced 6-in. (152-mm) thick bearing walls are limited to one story in height.

^C For these cases, spans are maximum wall heights.

the wall's vertical cross-sectional area and spaced not more than 48 in. (1,219 mm) apart).

In addition, buildings that rely on empirically designed masonry walls for lateral load resistance are allowed up to 35 ft (10.7 m) in height.

The 2003 IBC restricts empirical design to locations where the basic wind speed (three-second gust, not fastest mile) is less than or equal to 110 mph (79 m/s), as defined in *Minimum Design Loads for Buildings and Other Structures*, ASCE 7 (ref. 3). A wind speed of this velocity generally applies along the East and Gulf coasts of the United States.

The 2006 IBC further refines the empirical design limitations. Whereas with the 2003 IBC, the designer need only

check the SDC and basic wind speed, with the 2006 IBC, to use empirical design the designer must check:

- SDC,
- basic wind speed,
- building height, and
- location of gravity loads resultant.

The limitations based on SDC are the same as in the 2003 IBC, described above. Building height and basic wind speed conditions where empirical design is permitted under the 2006 IBC are summarized in Table 1.

The 2006 IBC also requires the resultant of gravity loads to fall within the kern of the masonry element, to avoid imparting tension to the element. This area is defined as: within the center third of the wall thickness, or, for foundation piers, within the central area bounded by lines at one-third of each cross-sectional dimension of the pier.

Table 4—Allowable Compressive Stress for Empirical Design of Masonry

Gross area compressive strength of unit, psi (MPa)	Allowable compressive stresses based on gross cross-sectional area, psi (MPa) ^A	
	Type M or S mortar	Type N mortar
Solid and Solidly Grouted Masonry (refs. 1, 6):		
Solid concrete brick:		
8,000 (55) or greater	350 (2.41)	300 (2.07)
4,500 (31)	225 (1.55)	200 (1.38)
2,500 (17)	160 (1.10)	140 (0.97)
1,500 (10)	115 (0.79)	100 (0.69)
Grouted concrete masonry:		
4,500 (31) or greater	225 (1.55)	200 (1.38)
2,500 (17)	160 (1.10)	140 (0.97)
1,500 (10)	115 (0.79)	100 (0.69)
Solid concrete masonry units:		
3,000 (21) or greater	225 (1.55)	200 (1.38)
2,000 (14)	160 (1.10)	140 (0.97)
1,200 (8.3)	115 (0.79)	100 (0.69)
Hollow walls (noncomposite masonry bonded ^B):		
Solid units:		
2,500 (17) or greater	160 (1.10)	140 (0.97)
1,500 (10)	115 (0.79)	100 (0.69)
Hollow Unit Masonry (Units Complying With ASTM C 90-06 or Later) (ref. 6)^C:		
Hollow loadbearing CMU, $t \leq 8$ in. (203 mm) ^D :		
2,000 (14) or greater	140 (0.97)	120 (0.83)
1,500 (10)	115 (0.79)	100 (0.69)
1,000 (6.9)	75 (0.52)	70 (0.48)
700 (4.8)	60 (0.41)	55 (0.38)
Hollow loadbearing CMU, 8 in. $< t < 12$ in. (203 to 305 mm) ^D :		
2,000 (14) or greater	125 (0.86)	110 (0.76)
1,500 (10)	105 (0.72)	90 (0.62)
1,000 (6.9)	65 (0.49)	60 (0.41)
700 (4.8)	55 (0.38)	50 (0.35)
Hollow loadbearing CMU, $t \geq 12$ in (305 mm) ^D :		
2,000 (14) or greater	115 (0.79)	100 (0.69)
1,500 (10)	95 (0.66)	85 (0.59)
1,000 (6.9)	60 (0.41)	55 (0.38)
700 (4.8)	50 (0.35)	45 (0.31)
Hollow walls (noncomposite masonry bonded ^B):		
$t \leq 8$ in. (203 mm) ^D	75 (0.52)	70 (0.48)
$8 < t < 12$ in (203 to 305 mm) ^D	70 (0.48)	65 (0.45)
$t \geq 12$ in (305 m.m) ^D	60 (0.41)	55 (0.38)
Hollow Unit Masonry (Units Complying With Previous Editions of ASTM C 90) (ref. 1)^C:		
Hollow concrete masonry units:		
2,000 (14) or greater	140 (0.97)	120 (0.83)
1,500 (10)	115 (0.79)	100 (0.69)
1,000 (6.9)	75 (0.52)	70 (0.48)
700 (4.8)	60 (0.41)	55 (0.38)
Hollow walls (noncomposite masonry bonded ^B):		
Hollow units	75 (0.52)	70 (0.48)

DESIGN PROVISIONS

Minimum Wall Thickness

Empirically designed (unreinforced) bearing walls of one story buildings must be at least 6 in. (152 mm) thick. For buildings more than one story high, walls must be at least 8 in. (203 mm) thick. The minimum thickness for unreinforced masonry shear walls and for masonry foundation walls is also 8 in. (203 mm). Note that the 2003 IBC allows shear walls of one-story buildings to have a minimum thickness of 6 in. (152 mm).

Lateral Support

Lateral support for walls can be provided in the horizontal direction by cross walls, pilasters, buttresses and structural frame members, or in the vertical direction by floor diaphragms, roof diaphragms and structural frame members, as illustrated in Figure 1. For empirically designed walls, such support must be provided at the maximum intervals given in Tables 2 and 3. Note that the span limitations apply to only one direction; that is, the span in one direction may be unlimited as long as the span in the other direction meets the requirements of Tables 2 or 3.

Allowable Stresses

Allowable stresses in empirically designed masonry due to building code prescribed vertical (gravity) dead and live loads (excluding wind or seismic) are given in Table 4.

Table 4 includes two sets of compressive stresses for hollow concrete masonry units (CMU). The first set, titled "Hollow Unit Masonry (Units Complying With ASTM C 90-06 or Later)" apply to most CMU currently available. The 2006 edition of the CMU specification, *Standard Specification for Loadbearing Concrete Masonry Units*, ASTM C 90 (ref. 7), included slightly reduced minimum face shell thickness requirements for CMU 10 in. (254 mm) and greater in width. These smaller face shells require a corresponding adjustment to the allowable compressive stresses. The values currently published in the 2006 IBC ("Hollow Unit Masonry (Units Complying With Previous Editions of ASTM C 90)" in Table 4), apply to the previous face shell thicknesses, and should only be used if the CMU to be used have the thicker face shells

^A Linear interpolation for intermediate values of compressive strength is permitted.

^B Where floor and roof loads are carried on one wythe, the gross cross-sectional area is that of the wythe under load; if both wythes are loaded, the gross cross-sectional area is that of the wall minus the area of the cavity between the wythes. Walls bonded with metal ties shall be considered as noncomposite walls unless collar joints are filled with mortar or grout.

^C Minimum unit face shell thicknesses, for units 10 in. (254 mm) and greater in width, were reduced beginning with ASTM C 90-06. Hence, minimum allowable compressive stresses should be reduced accordingly when using these units. See text for further information.

^D t = nominal unit thickness.

listed in previous editions of ASTM C 90. This distinction is not applicable to masonry that will be solidly grouted.

Calculated compressive stresses for both single and multiwythe walls are determined by dividing the design load by the gross cross-sectional area of the wall, excluding areas of openings, chases or recesses. The area is based on the specified dimensions of masonry, rather than on nominal dimensions. In multiwythe walls, the allowable stress is determined by the weakest combination of units and mortar shown in Table 4.

In addition, the commentary to *Building Code Requirements for Masonry Structures* (refs. 6, 8) contains additional guidance for concentrated loads. According to the commentary, when concentrated loads act on empirically designed masonry, the course immediately under the point of bearing should be a solid unit or be filled solid with mortar or grout. Further, when the concentrated load acts on the full wall thickness, the allowable stresses under the load may be increased by 25 percent. The allowable stresses may be increased by 50 percent when concentrated loads act on concentrically placed bearing plates that are greater than one-half but less than the full area.

Anchorage for Lateral Support

Where empirically designed masonry walls depend on cross walls, roof diaphragms, floor diaphragms or structural frames for lateral support, it is essential that the walls be prop-

erly anchored so that the imposed loads can be transmitted from the wall to the supporting element. Minimum anchorage requirements for intersecting walls and for floor and roof diaphragms are shown in Figures 2 and 3, respectively.

Masonry walls are required to be anchored to structural frames that provide lateral support by 1/2 in. (13 mm) diameter bolts spaced at a maximum of 4 ft (1.2 m), or with other bolts and spacings that provide equivalent anchorage. The bolts must be embedded a minimum of 4 in. (102 mm) into the masonry.

In addition, the 2006 IBC requires the designer to check the roof loading for net uplift and, where net uplift occurs, to design the anchorage system to entirely resist the uplift.

Shear Walls

Where the structure depends on masonry walls for lateral stability against wind or earthquake forces, shear walls must be provided parallel to the direction of the lateral forces as well as in a perpendicular plane, for stability.

Requirements for empirically designed masonry shear walls are shown in Figure 4.

Shear wall spacing is determined empirically by the length-to-width aspect ratio of the diaphragms that transfer lateral forces to the shear walls, as listed in Table 5. In addition, roofs must be designed and constructed in a manner such that they will not impose thrust perpendicular to the shear walls

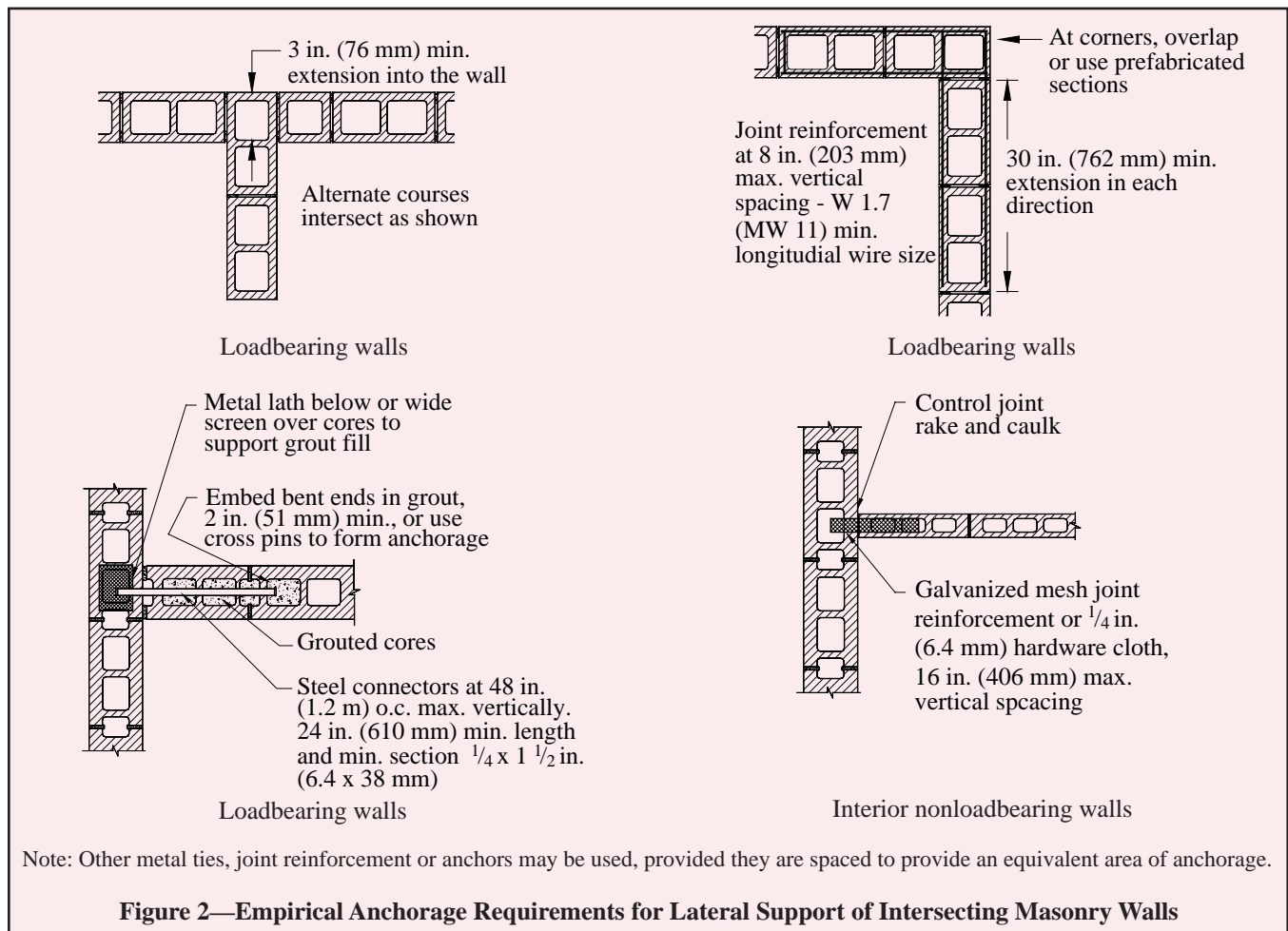

to which they are attached.

The height of empirically designed shear walls is not permitted to exceed 35 ft (10.7 m). The minimum nominal thickness of shear walls is 8 in. (203 mm), except under the 2003 IBC, which allows shear walls of one-story buildings to have a minimum thickness of 6 in. (152 mm).

Bonding of Multiwythe Walls

Wythes of multiwythe masonry walls are required to be bonded together. Bonding can be achieved using masonry headers, metal wall ties, or prefabricated joint reinforcement, as illustrated in Figure 5. Various empirical requirements for each of these bonding methods are given below.

Bonding of solid unit walls with masonry headers.

Where masonry headers are used to bond wythes of solid masonry construction, at least 4 percent of the wall surface of

each face must be composed of headers, which must extend at least 3 in. (76 mm) into the backing. The distance between adjacent full-length headers may not exceed 24 in. (610 mm) in either the horizontal or vertical direction. In walls where a single header does not extend through the wall, headers from opposite sides must overlap at least 3 in. (76 mm), or headers from opposite sides must be covered with another header course which overlaps the header below by at least 3 in. (76 mm).

Bonding of hollow unit walls with masonry headers.

Where two or more hollow units are used to make up the thickness of a wall, the stretcher courses must be bonded at vertical intervals not exceeding 34 in. (864 mm) by lapping at least 3 in. (76 mm) over the unit below, or by lapping at vertical intervals not exceeding 17 in. (432 mm) with units that are at least 50 percent greater in thickness than the units below.

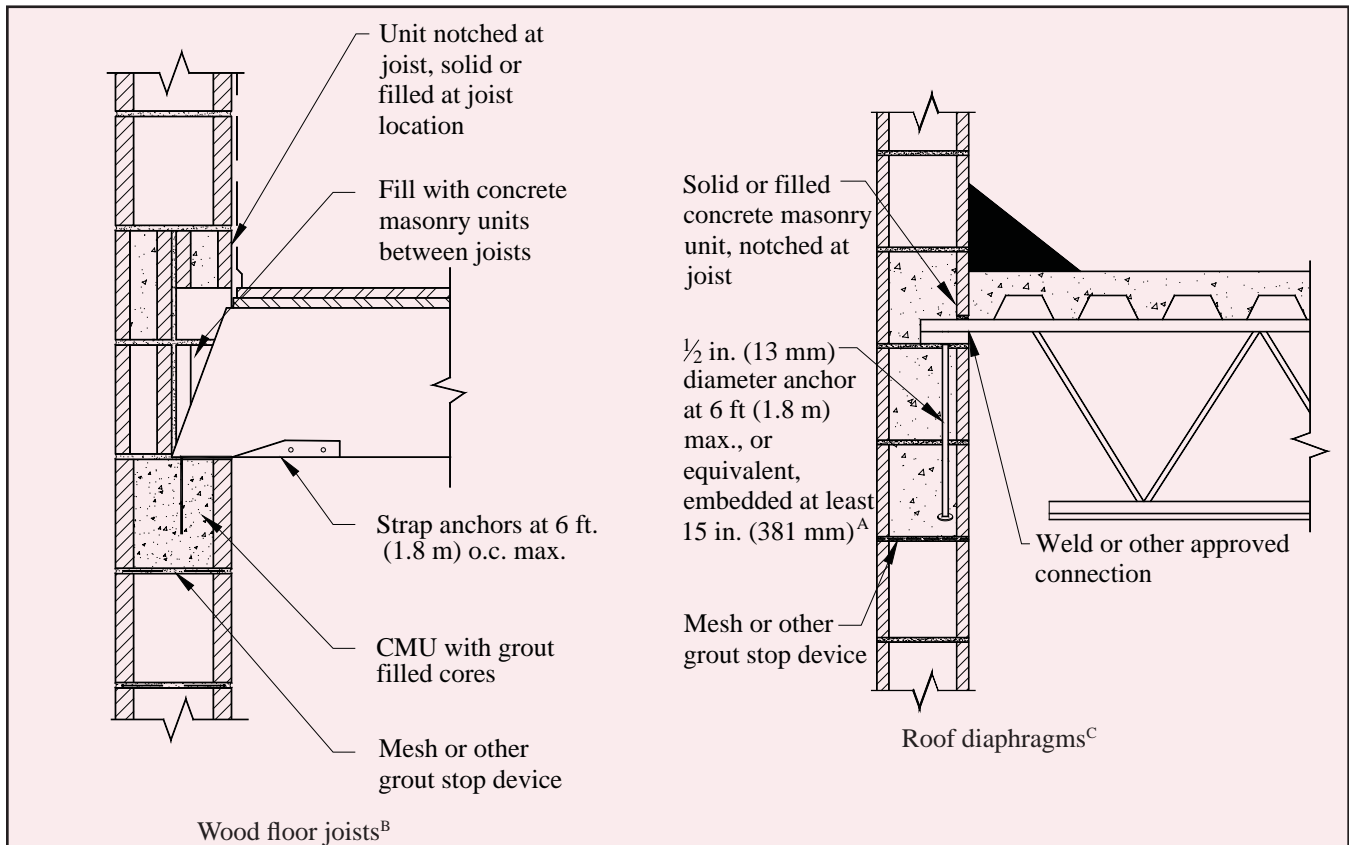

Notes:

^A As an alternative, the bolts can be hooked or welded to at least 0.2 in.² (No. 4, M#13) of bond beam reinforcement placed at least 6 in. (152 mm) from the top of the wall.

^B Wood joists anchored parallel to masonry walls require metal straps which extend over or under the joists and which are secured to at least three joists. Anchors must be spaced at a maximum of 6 ft (1.8 m). Blocking is required between joists at each strap anchor.

^C Steel floor joists which bear on and are anchored to masonry walls require ³/₈ in. (9.5 mm) reinforcing bars spaced a maximum of 6 ft (1.8 m) on center, or equivalent anchorage. Where joists are parallel to the wall, anchors must be located at joist cross bridging.

^D Refer to TEK 5-7A, *Floor and Roof Connections to Concrete Masonry Walls* (ref. 10) for other types of connections. Note that elements such as flashing, weeps, insulation, etc. are not shown for clarity.

Figure 3—Empirical Anchorage Requirements for Floor and Roof Diaphragms^D

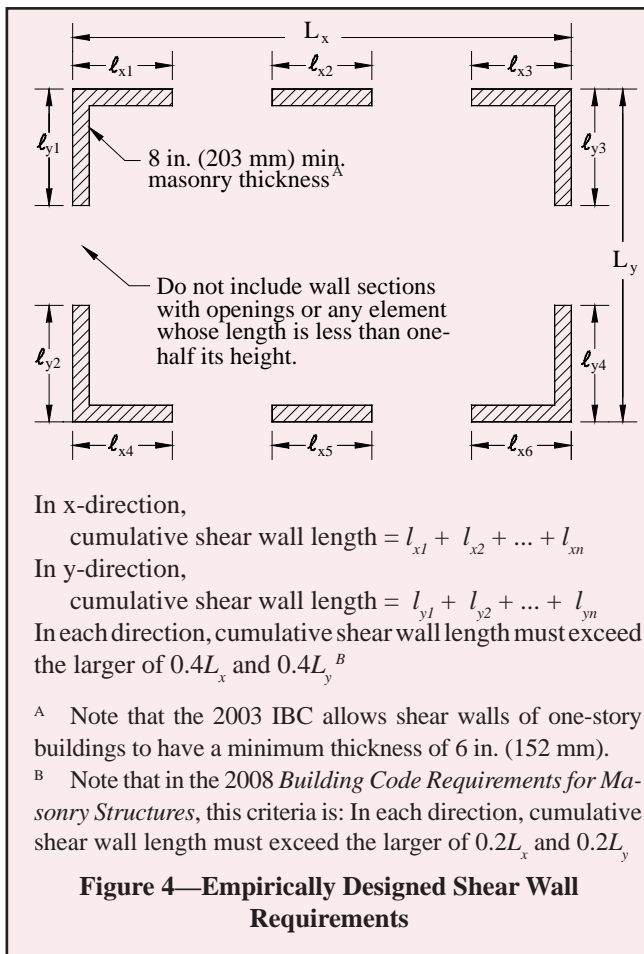
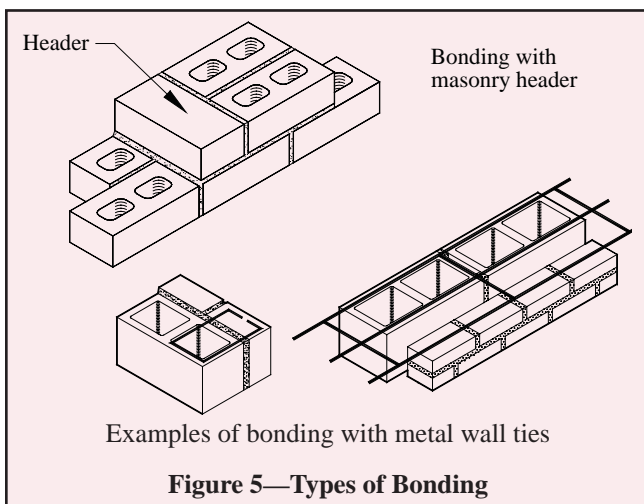

Table 5—Shear Wall Diaphragm Length-to-Width Ratios (ref. 1)

Floor or roof diaphragm construction	Maximum length-to-width ratio of diaphragm panel
Cast-in-place concrete	5:1
Precast concrete	4:1
Metal deck with concrete fill	3:1
Metal deck with no fill	2:1
Wood diaphragm	2:1



Bonding with metal wall ties (other than adjustable ties).

Wire size W2.8 (MW18) wall ties, or metal wire of equivalent stiffness, may be used to bond wythes. Each 4½ ft² (0.42 m²) of wall surface must have at least one tie. Ties must be spaced a maximum of 24 in. (610 mm) vertically and 36 in. (914 mm) horizontally. Hollow masonry walls must use rectangular wall ties for bonding. In other walls, ends of ties must be bent to 90° angles to provide hooks no less than 2 in. (51 mm) long. Additional bonding ties are required at all openings, and must be spaced a maximum of 3 ft (914 mm) apart around the perimeter and located within 12 in. (305 mm) of the opening. Note that wall ties may not include drips, and that corrugated ties may not be used.

Bonding with adjustable ties.

Adjustable ties must be spaced such that there is one tie for each 1.77 ft² (0.164 m²) of wall area, with maximum horizontal and vertical spacings of 16 in. (406 mm). The ties must have a maximum clearance between connecting parts of ¼ in. (1.6 mm), and, when pintle legs are used, at least two legs with a minimum wire size of W2.8 (MW18). The bed joints of the two wythes may have a maximum vertical offset of no more than 1¼ in. (32 mm). (See Reference 9 for an illustration of these requirements.)

Bonding with prefabricated joint reinforcement.

Where adjacent wythes of masonry are bonded with prefabricated joint reinforcement, there must be at least one cross wire serving as a tie for each 2⅔ ft² (0.25 m²) of wall area. The joint reinforcement must be spaced 24 in. (610 mm) or closer vertically. Cross wires on prefabricated joint reinforcement must be at least wire size W1.7 (MW11) and shall be without drips. The longitudinal wires must be embedded in the mortar.

Change in Wall Thickness

Whenever wall thickness is decreased, at least one course of solid masonry, or special units or other construction, must be placed under the thinner section to ensure load transfer to the thicker section below.

Miscellaneous Empirical Requirements

Following are additional empirical requirements in *Building Code Requirements for Masonry Structures*. Although not included explicitly in IBC Section 2109, the IBC includes a direct reference to *Building Code Requirements for Masonry Structures*.

Chases and Recesses

Masonry directly above chases or recesses wider than 12 in. (305 mm) must be supported on lintels.

Lintels

Lintels are designed as reinforced beams, using either the allowable stress design or the strength design provisions of *Building Code Requirements for Masonry Structures*. End bearing must be at least 4 in. (102 mm), although 8 in. (203 mm) is typical.

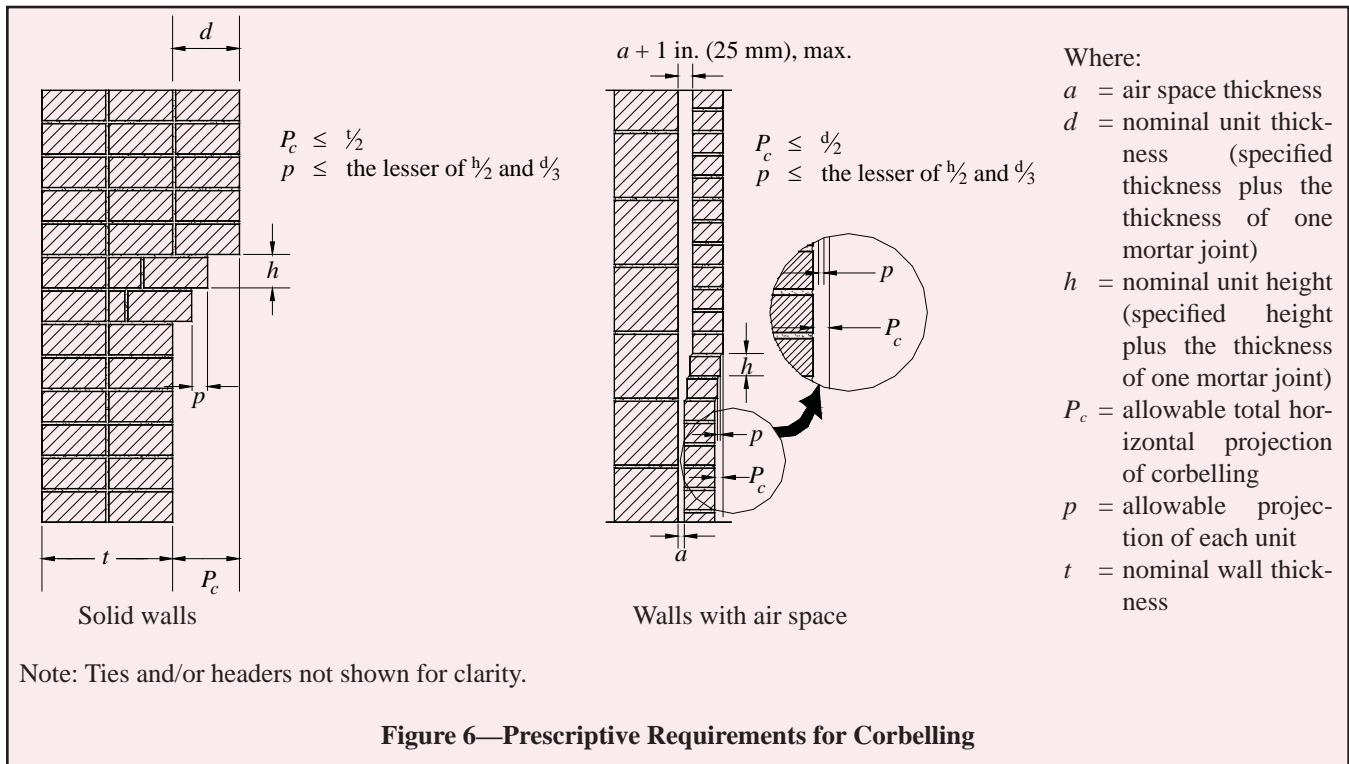

Support on Wood

Empirically designed masonry is not permitted to be supported by wood girders or other forms of wood construction, due to expected deformations in wood from deflection and moisture, causing distress in the masonry, and due to potential safety implications in the event of fire.

Corbelling

When corbels are not designed using allowable stress design or strength design, they may be detailed using the empirical requirements shown in Figure 6. Only solid or solidly grouted masonry units may be used for corbelling.

EMPIRICALLY DESIGNED PARTITION WALLS

In many cases, the building structure is designed using traditional engineered methods, such as strength design or allowable stress design, but the interior nonloadbearing masonry walls are empirically designed. In these cases, the partition walls are supported according to the provisions listed in Tables 2 and 3, but it is important that the support conditions provide isolation between the partition walls and the building's structural elements to prevent the building loads from being transferred into the partition. The anchor, or other support, must provide the required lateral support for the partition wall while also allowing for differential movement. This is in contrast to the "Anchorage for Lateral Support" section, which details anchorage requirements to help ensure

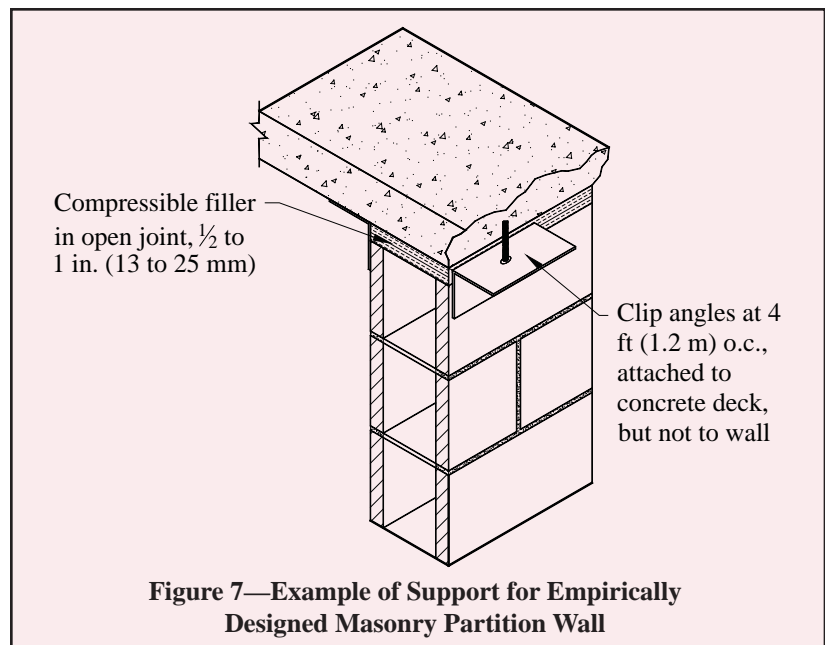

adequate load transfer between the building structure and the loadbearing masonry wall.

Figure 7 shows an example of such a support, using clip angles. C channels or adjustable anchors could be used as well. The gap at the top of the wall should be between 1/2 and 1 in. (13 and 25 mm), or as required to accommodate the anticipated deflection. The gap is filled with compressible filler, mineral wool or a fire-rated material, if required. Fire walls may also require a sealant to be applied at the bottom of the clip angles. This joint should not be filled with mortar, as it may allow load transfer between the structure and the partition wall.

REFERENCES

1. *International Building Code*. International Code Council, 2003 and 2006.
2. *Allowable Stress Design of Concrete Masonry Foundation Walls*, TEK 15-1B. National Concrete Masonry Association, 2001.
3. *Minimum Design Loads for Buildings and Other Structures*, ASCE 7-02. New York, NY: American Society of Civil Engineers, 2002.
4. *Minimum Design Loads for Buildings and Other Structures*, ASCE 7-05. New York, NY: American Society of Civil Engineers, 2005.
5. *Masonry Designer's Guide, 5th Edition*. Council for Masonry Research and The Masonry Society, 2007.
6. *Building Code Requirements for Masonry Structures*, ACI 530-08/ASCE 5-08/TMS 402-08. Reported by the Masonry Standards Joint Committee, 2008.
7. *Standard Specification for Loadbearing Concrete Masonry Units*, ASTM C 90-06. ASTM International, Inc., 2006.
8. *Building Code Requirements for Masonry Structures*, ACI 530/ASCE 5/TMS 402. Reported by the Masonry Standards Joint Committee, 2002 and 2005.
9. *Anchors and Ties for Masonry*, TEK 12-1A. National Concrete Masonry Association, 2008.
10. *Floor and Roof Connections to Concrete Masonry Walls*, TEK 5-7A. National Concrete Masonry Association, 2001.

Provided by:



NCMA and the companies disseminating this technical information disclaim any and all responsibility and liability for the accuracy and the application of the information contained in this publication.