

Technical Notes 19D - Brick Masonry Fireplaces, Part 1, Russian-Style Heaters [Jan. 1983] (Reissued June 1987)

Abstract: Brick masonry heaters may be used instead of conventional fireplaces to provide efficient supplemental heating for residential buildings. The design, detailing and construction of brick masonry fireplaces with baffle systems for combustion gases are discussed. Information regarding building code compliance, operation and the accessories required is presented with the basic principles by which these heaters provide supplemental heat for buildings.

Key Words: brick, buildings (codes), design, energy, fireplace, heating, masonry, mortar.

INTRODUCTION

There are many ways of improving the energy efficiency of fireplaces. Fireplace energy efficiency may be increased by providing glass screens or exterior air for draft and combustion; altering the shape of the firebox for increased radiant heating; incorporating baffles within the mass of the fireplace through which room air may be circulated for increased convective heating; or combinations of these features. These features, along with the proper design, construction and operation are discussed in *Technical Notes* 19 Revised, 19A Revised, and 19C, and are used to increase the efficiency of the wood-burning fireplace for heating the building or room. By altering the design of the fireplace to change the firebox shape and to replace the smoke chamber with a baffle system, greater heating and wood combustion efficiencies may be achieved. These alterations in the fireplace design result in a baffled brick masonry fireplace or brick masonry heater.

The brick masonry heater is a concept that has been used for centuries in Northern and Eastern Europe. Various styles of brick masonry heaters are often referred to as "Finnish" or "Russian" stoves, although they are used in many other countries such as Belgium, Germany, Switzerland, Sweden, The Netherlands and Norway. The basic principles used to obtain the high heating and combustion efficiencies are: 1) controlled air intake to the combustion chamber or firebox; and 2) a baffle system through which hot combustion gases are circulated. The combustion gases circulated through the baffle system heat the walls of the heater, which in turn heat the room. The basic concepts of design, construction and operation are simple, but there are several concerns which must be addressed to insure safety and durability. Two basic designs of brick masonry heaters are discussed in this *Technical Notes*: the "Russian Stove" with a *horizontal baffle system*, and the "Russian Stove" with a *vertical baffle system*. Other *Technical Notes* in this Series address the "Finnish" or "Fountain Style" brick masonry heater and modifications which may be applied to result in contemporary designs of brick masonry heaters.

These heaters are often referred to as stoves because as originally designed and built, they had provisions which permitted portions of the heater to be used for baking and cooking. This was done by circulating the hot combustion gases through baffles surrounding a brick oven and under exposed metal plates which were used for cooking. Such provisions are not practical for modern lifestyles because of the difficulty in controlling temperatures, thus the baking and cooking features are not addressed in this *Technical Notes*. However, the cooking features may be a consideration for designing and construction of an outside barbecue or cookstove. (See Reference 5).

GENERAL

Operation

Operation of a brick masonry heater is simple. The firebox is loaded with about 20 lb (9.1 kg) of wood. The fire is ignited. Once good combustion of the wood begins, the firebox door is closed and the air intakes are adjusted to the proper setting so that good combustion is maintained. The combustion gases exhaust from the rear of the firebox, circulated through the baffle system, warm the entire mass of the brick masonry heater and then are exhausted to the exterior of the building through a conventional chimney constructed on top of the heater. The fire

usually burns about 30 min when properly seasoned wood is used, and thus the firebox should be reloaded with 20 lb (9.1 kg) of wood four times in a 2-hr period for maximum heating. This procedure usually results in the brick masonry heater being sufficiently heated to keep a room, about 2400 ft³ (68 m³) warm for 8 to 12 hr. The operation will vary slightly, depending upon the size of the heater, the size of the room and the amount of heat needed to be comfortable. During the coldest months in severe climates such as those of Scandinavia, the heater usually needs to be operated twice a day, once in the morning and once in the evening. During the more moderate seasons, or in moderate climates, the heater may need to be operated only once, usually in the early evening, to supplement the heating requirements to maintain comfortable temperatures throughout the night. Other variations in operation, such as the number of loadings or the amount of wood used per loading during each firing, may also result in increased comfort. The operator should experiment with several variations of operation to determine the best performance for various seasons.

Properly operated, these brick masonry heaters are very effective in supplying radiant heat to the area of the building surrounding the heater. These heaters are not only good sources of heat, but have wood-burning efficiencies of 80 to 90 percent. (See Reference 3).

Building Code Requirements

There are no major model building code requirements which specifically address brick masonry heaters. For the most part, the building code requirements for fireplaces and chimneys are applicable to brick masonry heaters except for those requirements which address the dimensioning of the firebox and smoke chamber. All building code chimney requirements and clearances for combustibles are applicable.

There are, however, two concerns regarding safety which apply to the brick masonry heaters that are not presently listed in the major model building codes. The first concern is the integrity of the heater's enclosing walls. The walls forming the shell of the brick masonry heater should be at least two wythes of brick thick so that major cracks do not occur in the brick masonry heater. It is advisable to provide a nominal 1-in. (25 mm) air space between the two wythes. This will prevent cracks from penetrating through the interior to the exterior of the heater. Filling this 1-in. (25 mm) air space with compressible, non-combustible material, such as fiberglass insulation, will insure this separation. The two wythes should be tied together with corrosion-resistant metal ties. The insulation used to maintain a compressible space between the two wythes of brick should not affect the overall thermal performance of the brick masonry heater. To add to the integrity of the exterior wythe of the brick masonry heater, horizontal joint reinforcement should be placed in about every sixth course. Horizontal joint reinforcement should not be used on the interior wythe because the extreme differential thermal movements may deteriorate the mortar joints.

The second concern is the temperature of the exterior surfaces of the brick masonry heater walls. The highest surface temperatures of the walls are normally between 100°F (38°C) and 130°F (54 °C), but temperatures as high as 190°F (88°C) have been reported. Although these temperatures are much lower than those achieved with metal wood-burning stoves, sufficient clearances to combustibles should be maintained. A minimum 36-in. (900 mm) clearance is usually required between metal wood-burning stoves and combustibles. A minimum 12-in. (300 mm) clearance is recommended between the sides and back of the brick masonry heater and combustibles. At the floor line, this may be achieved by providing a 12-in. (300 mm) extended hearth. In front of the heater, a 20-in. (500 mm) extended hearth should be used. This is easily achieved when the heater is properly positioned in the room for maximum heating. This position is in the center of the room so that all four walls of the heater are providing radiant heat to the room. The brick masonry heater may also be installed against interior brick masonry walls.

DESIGN AND CONSTRUCTION

General

The brick masonry heater should always be positioned entirely inside the building. It should never be located on an exterior wall. When incorporated into an exterior wall, much of the radiant heat being supplied will be lost to the exterior. In addition, the location on an exterior wall will usually result in at least one cold surface on which a considerable amount of creosote may form. A creosote fire can reach temperatures which could result in cracks within the heater that may become too large to allow safe operation because combustion gases may leak into the room.

The actual dimensions of the masonry heater are limited by the available firebox door sizes, the number of baffles, and the height of the heater. For best performance, the heaters should not be more than one story in height, nor should they contain more than five baffle chambers. This is because the increased distances that the hot combustion gases must flow will result in a cooling of the gases. This causes a reduction in their heating capacity and could result in increased creosote deposits which may lead to potential fires.

There are two types of Russian-style brick masonry heaters: the vertically baffled heater shown in Figures 1 and 2, and the horizontally baffled heater shown in Figures 3 and 4. Many of the features are similar for both.

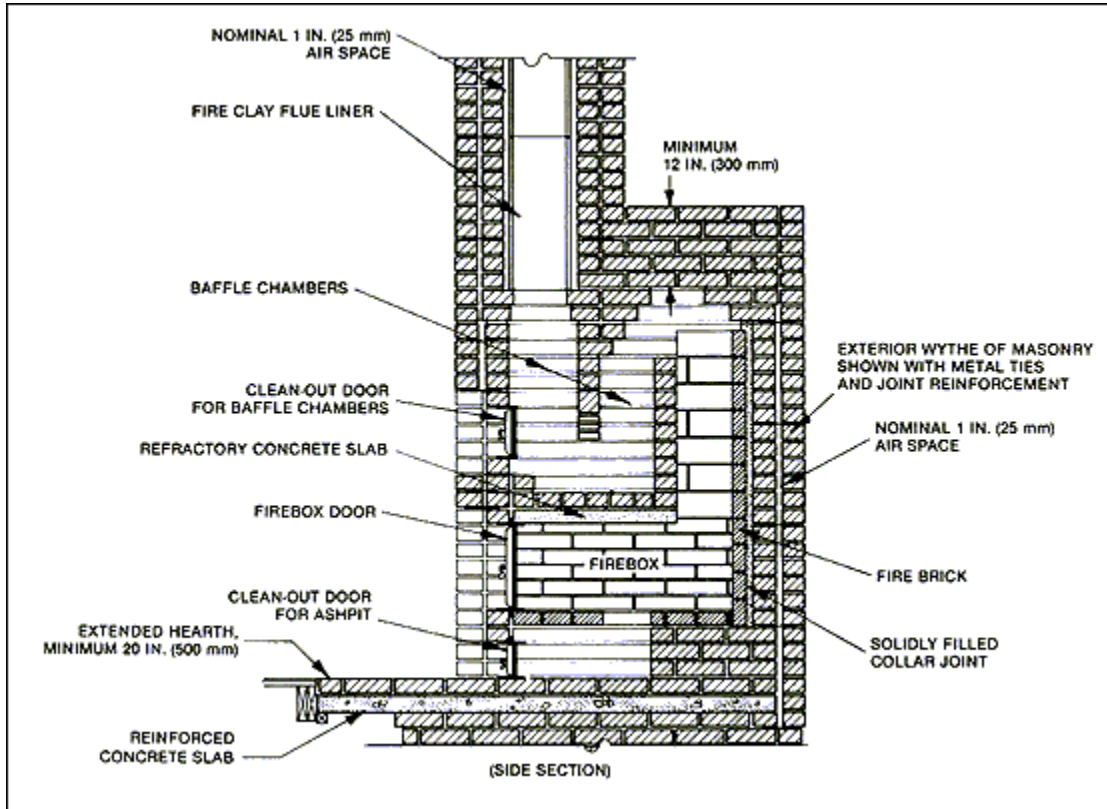

Brick Masonry Heater With Vertical Baffles

FIG. 1

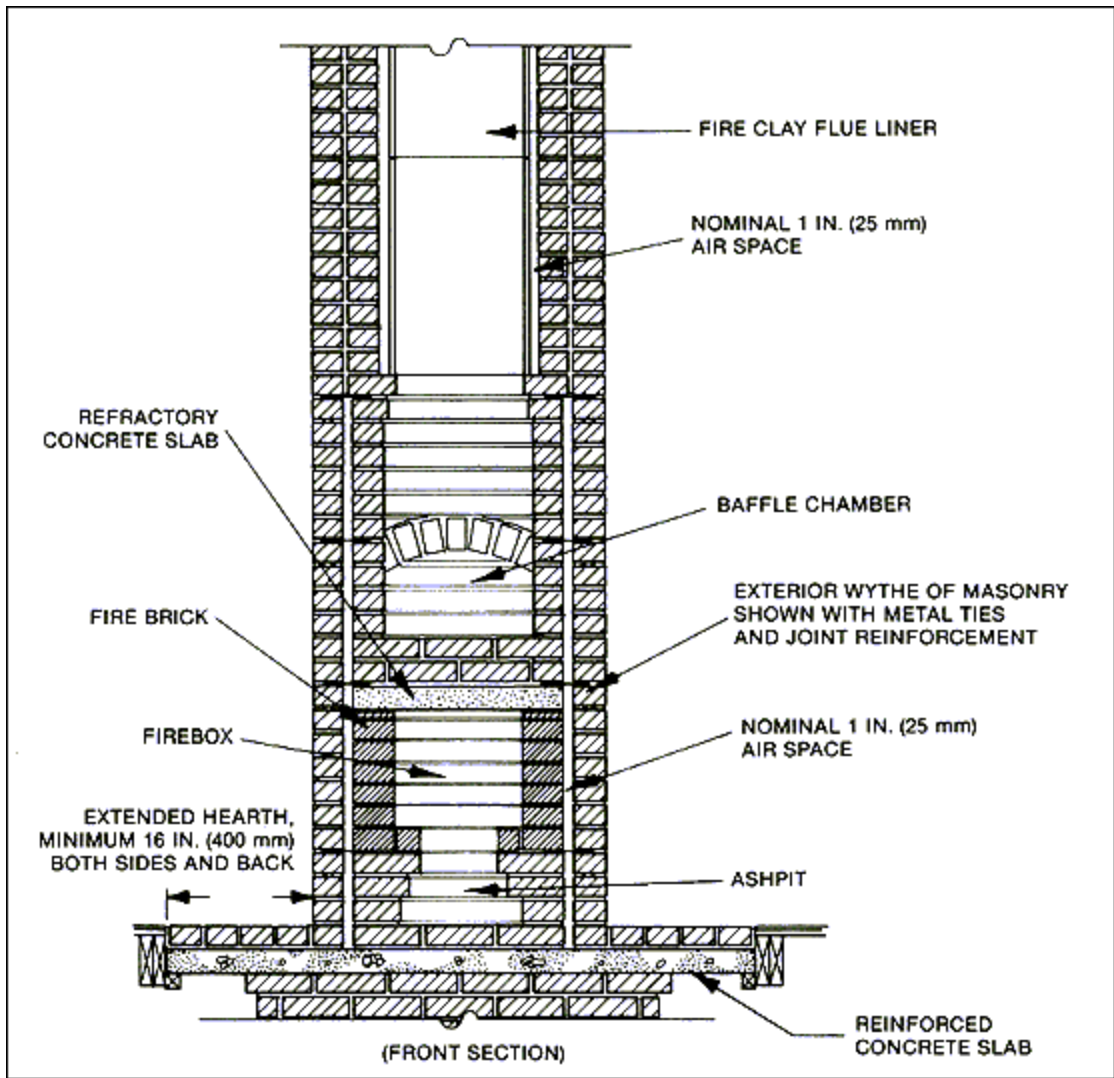

Brick Masonry Heater With Vertical Baffles

FIG. 2

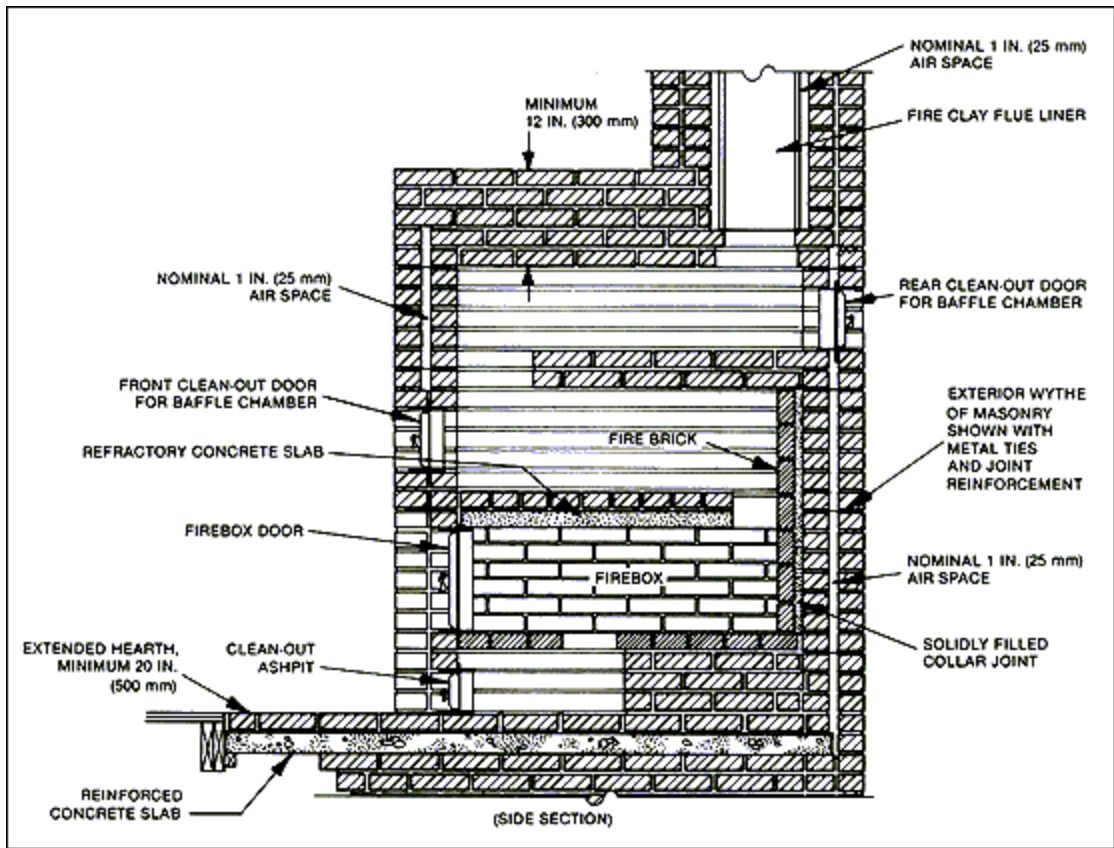

Brick Masonry Heater With Horizontal Baffles

FIG. 3

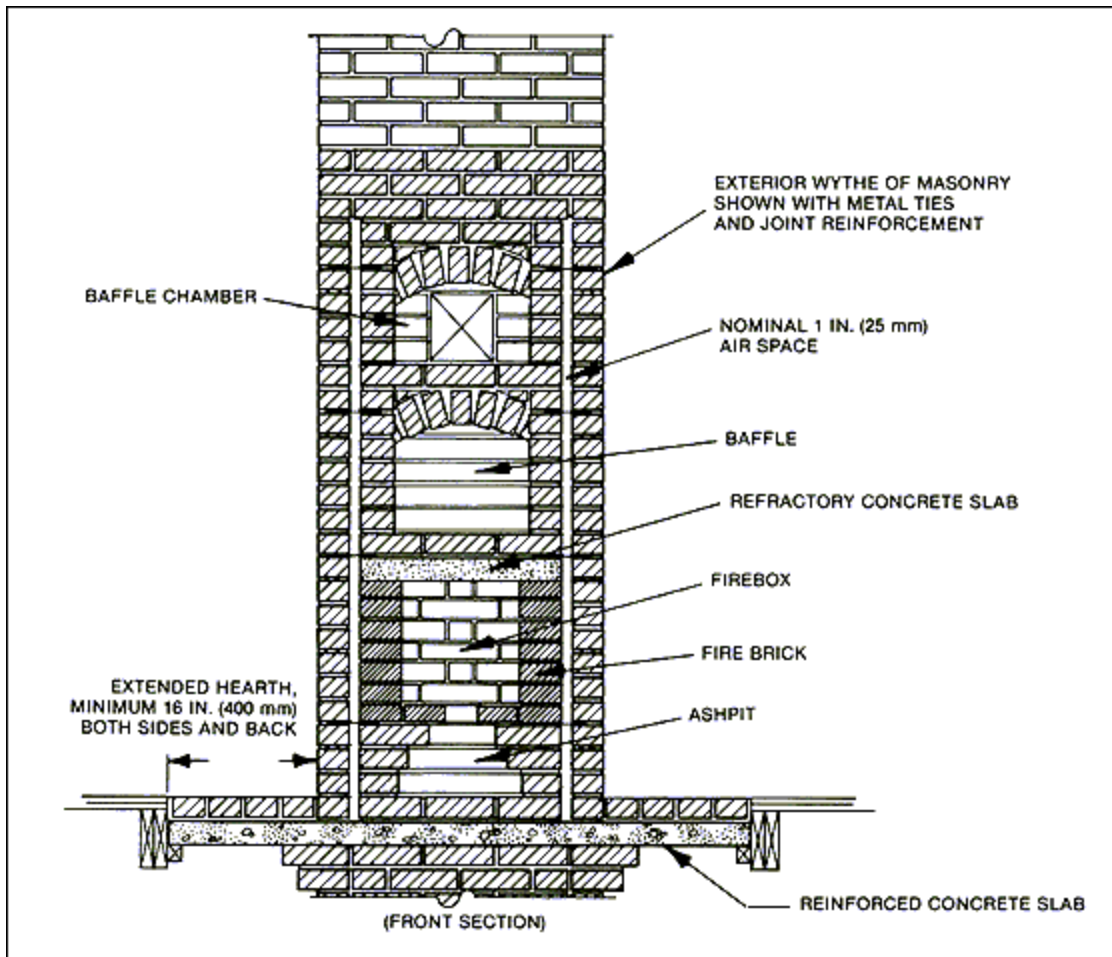

Brick Masonry Heater With Horizontal Baffles

FIG. 4

The most critical factors for the proper performance of brick masonry heaters are the gas flow through the baffle system and the draft of the chimney. All openings between the baffles and the area enclosed by the baffles should be at least 64 sq in. (40,000 mm²). The chimney should be constructed with clay flue liners with two wythes of brick surrounding the flue liners in such a way as to maintain a nominal 1-in. (25 mm) air space between the flue liners and the interior wythe of brick.

Clearances between the brick masonry heater exterior walls and any combustible materials should be at least 12 in. (300 mm). This will require the masonry heater to be either centrally located within a room, or located adjacent to a brick masonry or other non-combustible interior wall with at least a 1-hr fire rating. To ensure clearances, it may be beneficial to provide an extended hearth around the entire masonry heater. Construction using the proper clearances also maximizes the use of the warmed brick masonry surface as radiant heat sources.

Base Assembly

The base assembly includes the foundation, extended hearth, and ash drop. These features are the same for both the vertically and horizontally baffled Russian-style heaters.

Foundation. The foundation must be adequate to support the mass of the brick masonry heater and the masonry chimney. When designing the foundation, care should be taken to account for soil types and foundation conditions. Undisturbed or well-compacted soil will generally be sufficient, however, some types of soil or foundation conditions may require additional analysis, which may result in the need for special soil treatment or a unique foundation design.

Building codes generally require that the foundation be at least 12 in. (300 mm) thick, and in plan view, extend a minimum of 6 in. (150 mm) beyond each face of the masonry heater. The foundation should be positioned so that the bottom of the footing is below the frost line to reduce the possibility of "heaving."

Unless the foundation is a thickened slab in a newly constructed slab-on-grade structure, masonry is usually used to construct the base assembly to the height of the hearth support. The hearth support may be solid masonry construction carried up from the foundation to support the entire hearth area. To conserve materials, the masonry is usually brought up only equal to the dimensions of the masonry heater itself and the brick masonry of the base assembly is corbeled out to form the support for the extended hearth. See Figures 1 through 4. An individual corbel should not exceed one-half the unit height nor one-third of the unit thickness. The total projections of the corbel should not exceed one-half the thickness of the base assembly, nor one-half of the thickness of the solid masonry wall forming the base assembly. A further discussion of corbeling is provided in *Technical Notes 19A Revised*.

Extended Hearth. The extended hearth may be formed by placing a reinforced concrete slab on top of the corbeled base assembly. Non-combustible or removable forming should be placed so that it spans from the corbeled masonry assembly to the floor joists forming the opening for the brick masonry heater. Double joists should be used around the entire perimeter of the opening with a nailer to support the edge of the non-combustible extended hearth, as discussed in *Technical Notes 19A Revised*, except that the extended hearth for the brick masonry heater should be at least 20 in. (500 mm) in front of the firebox and 12 in. (300 mm) around the remaining perimeter of the heater. However, the extended hearth may be eliminated on one side, or the back of the heater if it is positioned against a non-combustible wall with a minimum fire rating of 1 hr. Once the reinforced concrete slab is installed, it may be finished with brick masonry pavers. If removable forming is used, the concrete slab used to support the extended hearth must be designed as a cantilever.

Ashpit. Once the extended hearth is installed, the brick masonry heater is laid out. The dimensions of the brick masonry heater are determined by the size of the available firebox doors and the number of baffles used in the masonry heater. The masonry heater, because of its efficient combustion of wood, does not require a large ashpit. The ashpit is usually formed by providing an opening, usually three courses of brick in height, and as wide as the firebox. This results in an ashpit which may be accessed from the front face of the brick masonry heater. The ashpit may be modified so that it is accessed from either side, or even from the rear of the masonry heater. Directly above the ashpit will be the base for the brick masonry heater firebox. Thus, the ashpit should be formed with corbeled brick masonry which will support the firebox base or a reinforced concrete slab may be used to serve as the top of the ashpit and the support for the firebox base. Using the reinforced concrete slab requires a formed opening in the slab for the ash drop.

Firebox Assembly

The dimensions of the firebox will depend on the size of the firebox doors, and either the length of the baffle chambers in the horizontally baffled masonry heater or the number of baffle chambers in the vertically baffled masonry heater. Thus, the baffle chambers need to be sized prior to laying out the masonry heater dimensions of the firebox.

There are several alternatives for constructing the firebox. The firebox base, sides and back should be lined with refractory units to obtain a thickness of at least 2 1/2 in. (63 mm). The refractory units on the rear wall of the firebox should extend to the top of the first baffle, as shown in Figures 1 and 2.

The top of the firebox may be formed either by using a precast reinforced refractory concrete slab, or by using refractory units which will span the width of the firebox. Both options require slabs or units wide enough to bear at least 2 in. (50 mm) on the side walls of the firebox liner. Another alternative is to form the top of the firebox with a masonry arch constructed of refractory brick units. This method of forming the top of the firebox is compatible with using several types of Dutch oven doors for the front of the fireplace.

Vertically Baffled. The baffle system for the vertically baffled Russian-style brick masonry heater is the easiest baffle system to build. There should be at least three vertical baffle chambers and usually no more than five, although successful systems have been built with up to nine. The greater the number of baffles, the longer the masonry heater needs to be fired to warm the entire mass of brickwork. This may decrease the efficiency of the system for both heating and combustion of the wood. It will also result in much hotter fires, which may augment the deterioration of the masonry heater. Another problem with using more baffles is that those portions of the heater which remain cooler invite creosote problems.

The baffles should be formed by using a single wythe of brick masonry to separate the baffle chambers, which are usually 64 to 144 sq in. (40,000-90,000 mm²) in cross-sectional area. These single wythe brick baffles should be masonry bonded to the interior wythe of the enclosing 8-in. (200 mm) brick masonry. Thus, thermal expansion of the baffles will impose a lateral load on the enclosing brick masonry which should be considered in the design. Major cracks in the heater should be avoided by keeping the wythes of the 8-in. (200 mm) thick enclosing brick masonry walls separated by a nominal 1-in. (25 mm) air space. To help insure that thermal expansion is provided for, this space may be filled with a compressible, noncombustible material. If a filler material is used, it may be easiest to construct the interior wythe with properly spaced ties, then wrap the heater with the compressible, non-combustible material, prior to constructing the exterior wythe.

Another problem is that thermal movement may separate the baffles from the interior wythe and allow lateral movement of the baffles. Thus, in addition to the masonry bond to the interior wythe of the enclosing walls, metal ties should also be installed every 8 in. (200 mm) vertically. These metal ties should be the only metal inside the interior wythe of the enclosing walls of the brick masonry heater, except for reinforcement in concrete slabs. The top of the openings through the baffles may be formed by corbeling brick units, as shown in Figures 2 and 4. Other alternatives for forming the baffle openings are shown in Figure 5. There should be at least 12 in. (300 mm) of brick masonry covering the top of the baffle chambers. Baffles with openings at the bottom are again single-wythe brick masonry walls. The openings in the bottom of baffles may be formed by using corbeled brick masonry, brick masonry arches, or by masonry units, or reinforced, precast concrete long enough to span the width of the baffle chamber and bear a minimum of 2 in. (50 mm) on each side of the interior wythe of brick masonry. At the front face of the masonry heater, near the bottom of the baffle chamber, a clean-out door is recommended so that any ash buildup may be removed from the baffle chamber.

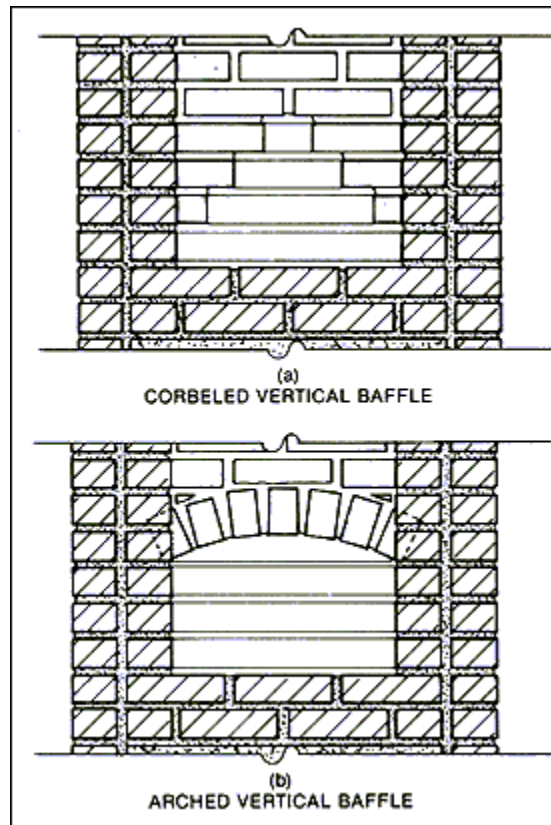

Typical Vertical and Horizontal Baffle Constructions

FIG. 5 a & b

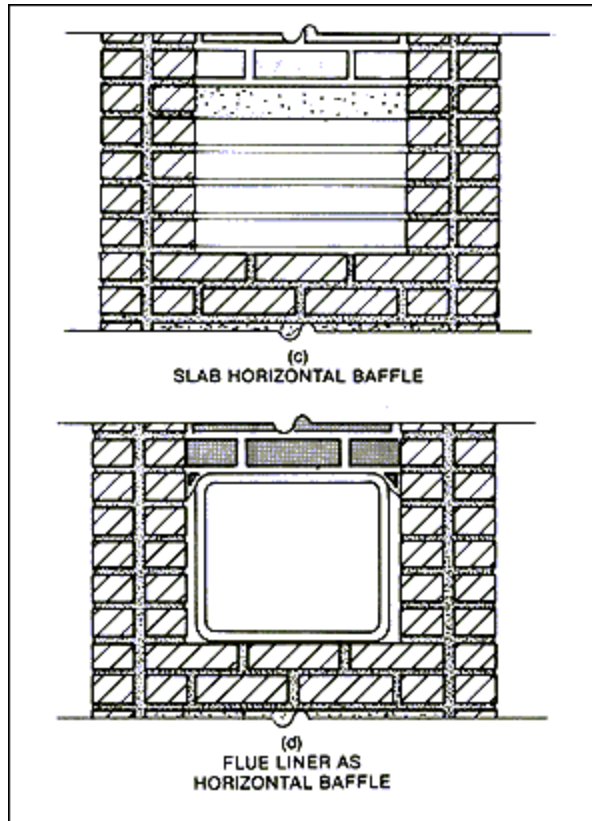

Typical Vertical and Horizontal Baffle Constructions

FIG. 5 c & d

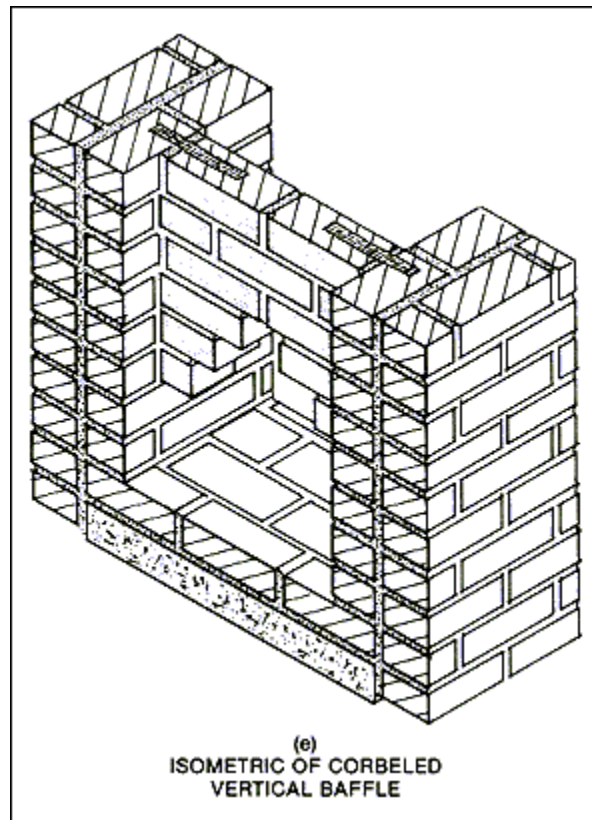

Typical Vertical and Horizontal Baffle Constructions

FIG. 5 e

The last upward baffle chamber in the baffle system, i.e., the chamber at the front face of the heater, becomes the support for the conventional flue liner. By corbeling the top course of the last baffle chamber, the support for a conventional clay flue liner is obtained.

Horizontally Baffled. The baffles for the horizontally baffled Russian-style brick masonry heater may be formed by using corbeled brick masonry, arches, a precast, reinforced concrete slab, or clay flue liners. When the slab is used, it should be sufficiently wide to span across the width of the baffle chamber and bear at least 2 in. (50 mm) on the interior wythe of each side wall of the baffle chamber. Arches or corbels used to form the air passageway may be started from the interior wythe of the baffle chamber wall. These are shown in Figures 3 and 5. The horizontal baffle system requires a clean-out at the bottom of each baffled area. The side and either the front or rear baffle chamber walls (depending on the number of horizontal baffles) and the top of the last baffle should be used to support the conventional flue liner for the chimney. There should be at least a 12-in. (300 mm) thickness of brick masonry forming the top of the last horizontal baffle.

Clean-Outs. Clean-outs for the baffle chamber of either Russian-style brick masonry heater are optional. Usually, when properly seasoned wood is used under adequate air intake conditions, and at high temperature, creosote should not form in large quantities. In addition, because of the baffles, most soot and ash remain in the firebox. However, the installation of clean-outs is recommended to observe any buildup. If a buildup is occurring, the operation of the stove should be modified, so that the buildup no longer occurs. This may be accomplished by increasing the amount of combustion air being supplied through the firebox doors.

Crown. The crown of the Russian-style brick masonry heater should terminate at least 12 in. (300 mm) below the ceiling of the room. Multi-story heaters are not recommended because the distance the combustion gases must flow, from the firebox through the baffles to the chimney, cools the gases and decreases performance. Typically, the distance from the firebox through the baffle chambers to the chimney should be limited to no more than 16 ft (4.9 m). The crown should be at least 12 in. (300 mm) thick, starting from the highest point of the baffle chamber. The crown may be flat, but is often constructed as an arch for esthetics.

Chimney. The chimney for the Russian-style brick masonry heater is similar to those used for fireplaces. The chimney should be constructed with clay flue liners and 8 in. (200 mm) of brick masonry surrounding the flue liner in such a way that a nominal 1-in. (25 mm) air space is maintained between the flue liner and the surrounding brick masonry. The 8-in. (200 mm) chimney wall is recommended to help keep the chimney at a higher temperature to increase performance. Additional information on chimney design and construction is provided in *Technical Notes 19B Revised*.

The chimney height required for draft is usually higher than that necessary for conventional fireplaces, but following the building code requirements for fire safety will usually result in a sufficiently high chimney. Most codes require that the chimney terminate at least 3 ft (1 m) above the roof at the highest point of exit and at least 2 ft (600 mm) above any portion of the building or any adjacent structure within 10 ft (3 m) of the chimney. If the draft is determined to be inadequate by a smoke test, the chimney height should be increased to provide adequate draft.

The chimney for the Russian-style masonry heater must be free to move vertically to allow for the vertical thermal expansion of the masonry heater supporting it. This requires properly sealed flashing and counter-flashing where the chimney penetrates the roof line.

Esthetics

An additional consideration in the design of a brick masonry heater is the esthetics. Figures 1 through 4 show the basic heater design for function. This results in a rectangular mass of brick within the building, which may or may not be esthetically pleasing. Incorporating arches, corbels, racks and mantels into the design may greatly increase the esthetic value.

SELECTION OF MATERIALS

General

The design and construction of a brick masonry heater using products available in the United States is slightly different than the construction of the heater in Europe. European heaters are usually constructed using a single wythe of 5-in. (125 mm) thick brick for the exterior shell. The exterior brick is then often covered with glazed ceramic tiles, set in high temperature-resistant epoxy grout. Using a single wythe around the firebox and baffles may result in cracking. The positive draft through the firebox and baffle chambers results in little danger of toxic gases escaping into the occupied areas of the building. By using multiple wythes for the exterior shell, the potential for a crack penetrating completely through the heater is substantially reduced. Single-wythe construction of masonry heaters is therefore *not* recommended.

In addition to the construction differences of the exterior shell, the accessories used in Europe are not usually available in North America. There are methods to modify the design and construction so that products readily available in North America may be used in the brick masonry heater. The options also exist to either import the accessories or to fabricate accessories similar to those used in Europe. However, these options are usually uneconomical. Additional information regarding accessories may be obtained from the cited references.

Brick

Most building codes require that solid masonry units be used for fireplace construction. Solid brick should conform to ASTM C 216 or C 62 for facing brick or building brick, respectively. Hollow brick conforming to ASTM C 652 may be used if vertical reinforcement is required.

If vertical reinforcement is to be used to provide resistance to cracking, the brick masonry heater may be constructed using a single wythe of reinforced, grouted hollow brick. Reinforced hollow brick masonry should be constructed using at least nominal 8-in. (200 mm) thick hollow brick units. The shell of the heater may also be constructed of a vertically and horizontally reinforced, fully grouted, multi-wythe brick masonry wall. The grout core should be at least 2 in. (50 mm) thick and the brick wythes must be properly tied.

When face brick or building brick is used, the walls of the heater should be at least two wythes thick, using nominal 4-in. (100 mm) or 3-in. (75 mm) thick brick. Grade SW brick should be used because of its greater durability.

Refractory brick, conforming to ASTM C 64, medium duty, should be used for the firebox. The lining for the back of the firebox should extend to the top of the first baffle chamber. These areas are exposed to the greatest amount of heat and the refractory units are more resistant to heat and thermal shock.

Salvaged or used brick should *not* be used because they usually will not bond well with the mortar and lack the durability necessary for satisfactory performance. The use of salvaged brick is discussed in *Technical Notes 15*.

Mortar and Grout

It is most convenient and economical to use only one type of mortar for the entire brick masonry heater and chimney construction. This becomes difficult when constructing a brick masonry heater because of the specific requirements of each component. The portions of the heater consisting of building, face or hollow brick should be constructed using a Type N, portland cement-lime mortar, conforming to the proportion specifications of ASTM C 270 or BIA M 1-72. The same mortar should be used for the chimney brickwork except when wind loads exceed 25 psf (1.2 kPa). Where high wind loads exist, a Type S, portland cement-lime mortar should be used. It may be desirable to use high temperature-resistant mortars, such as calcium aluminate mortars, for the interior wythes and baffles of the brick masonry heater. Such mortars will increase the durability of the heater.

The firebox and all other components constructed of refractory units should be set using a fireclay mortar, conforming to ASTM C 105, medium duty. Other refractory mortars have also been successfully used, and thus any high temperature-resistant mortars that have performed well may be used. It is not within the purview of the Brick Institute of America to recommend proprietary products. The selection of the proper mortars should be determined by an experienced fireplace expert for the specific design being considered.

For reinforced brick masonry, all cores of hollow brick masonry construction and the grout space of hollow wall construction must be fully grouted. The grout should conform to ASTM C 476.

Flue Liners

Clay flue liners used for the chimney or to form the baffle chambers should conform to ASTM C 315. They should be thoroughly inspected just prior to installation for cracks or other damage which might contribute to smoke or flue gas leakage. All flue liners should be set in fireclay mortar.

Steel Lintels and Dampers

Steel lintels should not be used inside the exterior 4-in. (100 mm) wythe of the brick masonry heaters because of the high temperatures involved. The difference in thermal expansion characteristics could cause cracking of the brick masonry heater. For the same reason, metal dampers are not used within the Russian-style fireplace. Lintels of corrosion-resistant steel, conforming to ASTM A 36, should be used over the firebox door and clean-out door openings.

Ties and Reinforcement

Corrugated Metal Ties. Corrugated metal ties may be used to attach the baffles to the interior wythe of the heater walls and to tie the two wythes of the exterior walls of the heater together. Ties should be corrosion-resistant, and at least 22 ga, 7/8 in. (22.2 mm) wide, and 6 in. (150 mm) long.

Wire Ties. Wire ties are preferred for tying the brick masonry together. Wire ties should be at least 9 ga and corrosion-resistant. The ties should be fabricated from wire conforming to ASTM A 82 or ASTM A 185.

Prefabricated Joint Reinforcement. Prefabricated joint reinforcement should be used for the exterior wythe of the heater walls. The joint reinforcement should be fabricated from wire which complies with ASTM A 82 or ASTM A 185, and should be corrosion-resistant.

Reinforcement. Reinforcement should conform to any of the following applicable standards:

Standard Specifications for Deformed and Plain Billet-Steel Bars for Concrete Reinforcement-ASTM A 615.

Standard Specifications for Rail-Steel Deformed and Plain Bars for Concrete Reinforcement-ASTM A 616

Standard Specifications for Axle-Steel Deformed and Plain Bars for Concrete Reinforcement-ASTM A 617

Corrosion Resistance. Corrosion resistance is usually provided by a copper or zinc coating, or by using stainless steel. To ensure adequate resistance to corrosion, coatings or materials should conform to any of the following applicable standards:

Zinc-Coating of Flat Metal-ASTM A 153, Class B-1, B-2, or B-3

Zinc-Coating of Wire-ASTM A 116, Class 3

Copper Coated Wire-ASTM B 227, Grade 30 HS

Stainless Steel-ASTM A 167, Type 304

Firebox Doors. The doors for the firebox opening may be fabricated locally, ordered from Europe or may be conventional metal Dutch oven doors, which are the most economical. The brick masonry heater is not designed for airtight combustion and thus the doors need to be equipped with operable vents to control air intake into the firebox.

The size of the firebox door is a major consideration in the design of the brick masonry heater. The height and width of the firebox and the width of the baffle chambers are usually the same as, or just slightly larger than, the firebox door. Other alternatives exist for the firebox design and firebox doors, and are discussed in other *Technical Notes* in this Series. The typical European-style door is shown in Figure 6.

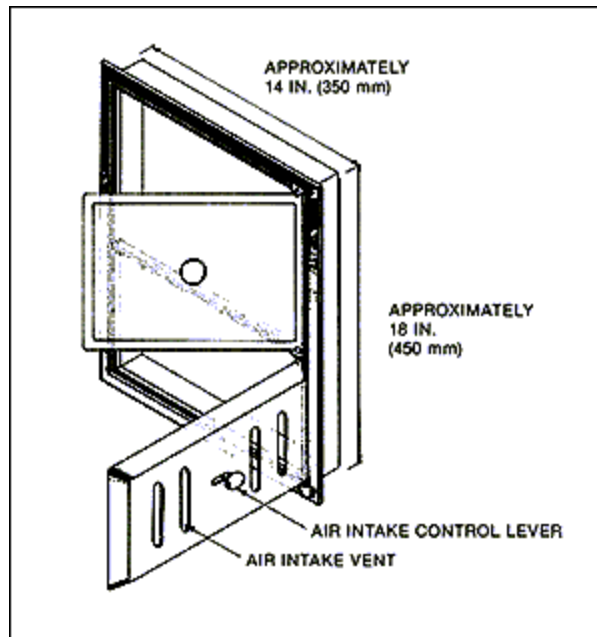

Typical Firebox Door

FIG. 6a

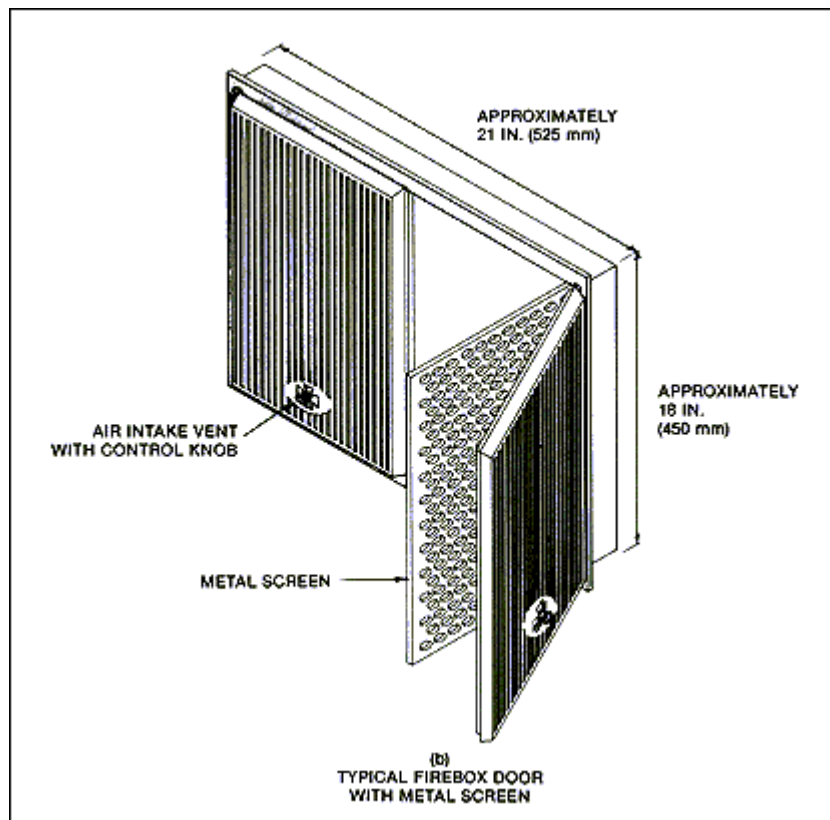

Typical Firebox Door With a Metal Screen

(Fire Box and Clean-Out Doors)

FIG. 6b

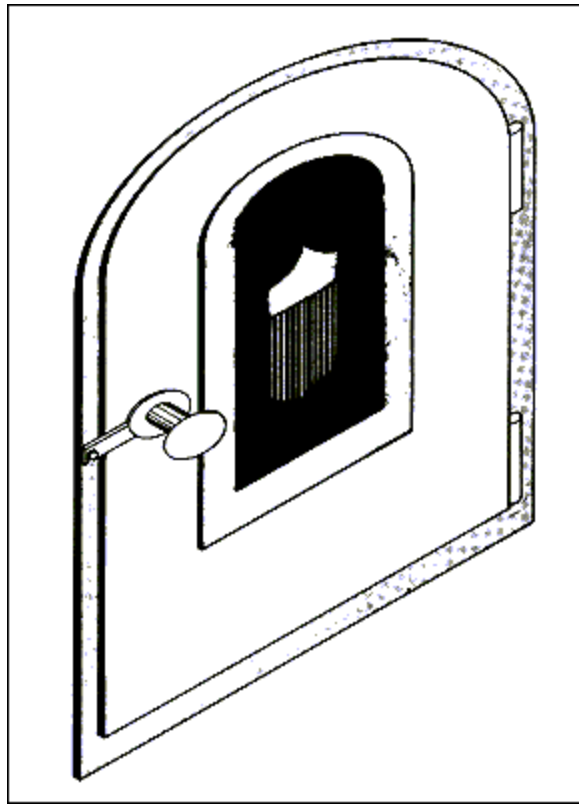

Typical Dutch Oven Style Door

FIG. 6c

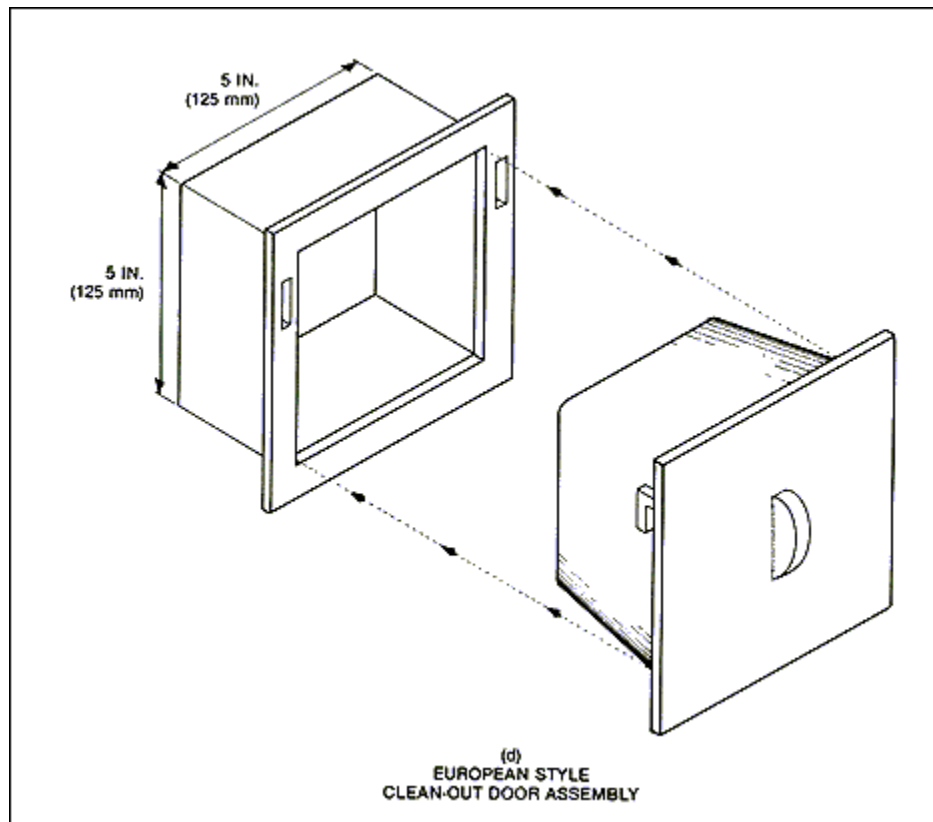

European Style Clean-Out Door Assembly

(Fire Box and Clean-Out Doors)

FIG. 6d

Clean-out Doors. Clean-out doors used in Europe for the baffle system are tight-fitting doors which have tapered latches to ensure tightness of fit. These doors are shown in Figure 6. Conventional clean-out doors may be used, but to ensure tightness, refractory units should be placed within the door opening with a compressible, non-combustible material or set in a sand-lime mortar. This is shown in Figure 7. The refractory units increase the resistance to combustion gas leaks, provide protection to the metal door from high temperatures, and may easily be removed and replaced when cleaning, if necessary. Clean-out doors for the ash drop may be conventional clean-out doors, installed in the conventional manner.

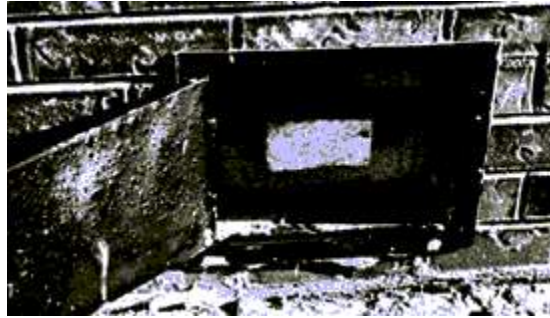

Clean-Out Door Backed with Firebrick

FIG. 7

SUMMARY

The information and suggestions contained in this *Technical Notes* are an accumulation of the available information within the Brick Industry Association on Russian-style fireplaces and brick masonry heaters. The information is based on empirical data from actual performance of such heaters here in North America and in Europe. The information and recommendations are provided for use with good technical judgment for the design and construction of a functional brick masonry heater. Final decisions on the design and use of materials as discussed in this *Technical Notes* are *not* within the purview of the Brick Industry Association, and must rest with the project designer, owner, or both.

REFERENCES

1. "Complete Plans and Instructions for Construction and Operation of a Masonry Stove, Finnish, or Russian Fireplace," by Basilio Lepuschinko, Richmond, Maine, 1980.
2. "How to Build a Russian Fireplace," by Jay Jarpe, Los Lunas, New Mexico, 1980.
3. "A Russian-Type Fireplace Demonstration and Workshop," New Mexico Energy Institute, The University of New Mexico, Albuquerque, New Mexico, 1981.
4. "On Building Masonry Firestoves," by J. Patrick Manley, *Farmstead Magazine*, Fall Issue 1980, No. 34.
5. "What's So Hot About A Russian Fireplace?" by M. R. Allan, *Yankee Magazine*, Dublin, New Hampshire, February 1978.