



TECHNICAL NOTES on Brick Construction

1850 Centennial Park Drive, Suite 301, Reston VA 20191 | www.gobrick.com | 703-620-0010

Technical Notes 21A -BRICK MASONRY CAVITY WALLS -SELECTION OF MATERIALS

Feb. 1999

Abstract: The selection of quality materials is essential to the successful performance of brick masonry cavity walls. Careful evaluation of materials is required in order to obtain the high performance level associated with these wall systems. This Technical Notes addresses selection of appropriate materials, referencing ASTM standards when applicable.

Key Words: air retarder, brick, cavity wall, expansion joint, flashing, insulation, materials, mortar, ties, vapor retarder, weep holes.

INTRODUCTION

Brick masonry cavity walls have always been a popular choice with structural frames and as bearing walls, particularly for use in commercial construction. These wall types are selected for their superior in-service performance resulting from such properties as excellent moisture penetration resistance, thermal capabilities, sound transmission resistance and fire resistance.

All of these qualities of brick masonry cavity walls depend on four key elements: design, material selection, detailing and construction. Proper design will not compensate for inadequate material selection or detailing. Conversely, superior design, material selection, or detailing will not compensate for poor construction practices. The use of quality materials in the construction of brick masonry cavity walls is of prime importance. The selection of materials is even more critical now that masonry design standards and model codes put greater emphasis on material properties for design requirements. This Technical Notes addresses proper material selection. Properties of brick masonry cavity walls, adequate detailing and construction are addressed in other Technical Notes in this series.

GENERAL

The standards of choice for quality construction materials are those developed by the American Society for Testing and Materials (ASTM). ASTM has developed standard specifications for virtually all construction-related building materials. These specifications are based on laboratory tests, field experience and, in the case of brick masonry units, are the result of the legacy of masonry's long successful performance. ASTM standards are consensus documents that set minimum acceptable requirements for materials of construction. ASTM standards allow for different performance levels and it may be necessary to choose a level in the project specifications to meet the particular requirements for an individual project. ASTM standards should be reviewed and understood before they are incorporated into a project specification. It must also be understood that the use of ASTM standards does not guarantee the desired performance, even though all materials may meet the specifications.

There are additional materials available that are not addressed in this Technical Notes that would accomplish the goal of providing proper material selection. Lack of specific reference to a material does not preclude its use for brick masonry cavity walls.

MASONRY UNITS

The exterior wythe of a brick masonry cavity wall may be of solid or hollow brick. The interior wythe can be solid brick, hollow brick, structural clay tile or hollow or solid concrete masonry units.

Brick

Solid brick units should meet the requirements of ASTM C 216 Specification for Facing Brick when appearance is a factor or C 62 Specification for Building Brick when appearance is not important. Hollow brick units should meet the requirements of ASTM C 652 Specification for Hollow Brick. For these specifications, Grade SW should be specified for all exterior exposures in areas that experience freeze/thaw cycling. Grade MW units may be used for the interior wythe. Ceramic glazed solid brick used for both the exterior and interior wythe of cavity walls should meet the requirements of ASTM C 1405 Specification for Glazed Brick (Single Fired, Solid Brick). Other ceramic glazed units should conform to ASTM C 126 Specification for Ceramic Glazed Structural Clay Facing Tile, Facing Brick and Solid

Masonry Units. Information on classification and selection of brick can be found in Technical Notes 9A and 9B, respectively. Further information on brick masonry material selection for adequate strength and compliance with the Masonry Standards Joint Committee (MSJC) Code and Specification can be found in Technical Notes 3 Series.

Concrete Masonry Units

Concrete masonry units are usually used for the interior wythe of a cavity wall in combination with a brick masonry exterior. They may also be used as accent bands in the exterior brick wythe. Hollow or solid concrete masonry units should conform to ASTM C 55 Specification for Concrete Building Brick, ASTM C 90 Specification for Loadbearing Concrete Masonry Units or ASTM C 129 Specification for Non-Loadbearing Concrete Masonry Units. Non load-bearing concrete masonry units are usually specified for the interior wythe when the brick and block cavity wall is used as infill walls for concrete or steel frame structural systems if shear loads are not transmitted to that wythe.

Structural Clay Tile

Structural clay tile has been used as a backing material for cavity wall construction. Structural clay tile for this purpose should conform to ASTM C 126, ASTM C 34 Specification for Structural Clay Load-Bearing Wall Tile or ASTM C 212 for Structural Clay Facing Tile. Clay tile units under ASTM C 126 and ASTM C 212 are commonly used for the interior wythe of a cavity wall when left exposed for architectural appearance reasons.

MORTAR

The strength and moisture penetration resistance of a brick masonry cavity wall are affected by the mortar selection and compatibility with the brick units. Portland cement-lime, mortar cement, or masonry cement mortars can be used. However, mortars with an air content less than 12 percent are recommended for their superior bond strength and resistance to moisture penetration. The MSJC Code requires that the allowable flexural tensile stresses be reduced by approximately 50 percent for assemblies constructed with masonry cement mortars or portland cement-lime mortars that have air entrainment. In addition, some building codes prohibit the use of masonry cement mortars and all Type N mortars in Seismic Performance Categories D and E (formerly Seismic Zones 3 and 4).

Mortar should meet the proportion requirements of ASTM C 270 Specification for Mortar for Unit Masonry as shown in Table 1. Mortar type selection should be based on project requirements, such as strength and compatibility with a particular brick unit. Types N or S mortars are typically used in brick masonry cavity walls. See Technical Notes 8 Series for more detailed information on mortar types and selection.

TABLE 1
Mortar Proportion Requirements

Mortar	Type	Portland Cement or Blended Cements	Masonry Cement or Mortar Cement			Hydrated Lime or Lime Putty	Aggregate Ratio (measured in Damp, Loose Conditions)
			M	S	N		
Cement-Lime	M	1	—	—	—	¼	Not less than 2¼ and not more than 3 times the sum of the separate volumes of cementitious materials
	S	1	—	—	—	over ¼ to ½	
	N	1	—	—	—	over ½ to 1¼	
	O	1	—	—	—	over 1¼ to 2½	
Masonry Cement or Mortar Cement	M	1	—	—	1	—	
	M	—	1	—	—	—	
	S	½	—	—	½	—	
	S	—	—	1	—	—	
	N	—	—	—	1	—	
	O	—	—	—	1	—	

WALL TIES

Wall ties must provide two important functions: 1) distribute lateral loads between wythes; and 2) accommodate differential movement between wythes. For a wall tie system to provide these functions, it must:

- 1) be securely attached and embedded in the masonry wythes;

- 2) be placed at the appropriate spacing;
- 3) have sufficient strength to transfer lateral loads with minimal deformations;
- 4) have a minimal amount of mechanical play, if an adjustable tie;
- 5) have sufficient corrosion resistance;
- 6) be easily installed without damage to the tie system or other wall components; and
- 7) not compromise expected wall performance.

Although cost of the wall tie should be considered, this should not be the controlling factor since the cost of the wall tie system is small as compared to the total cost of the wall assembly.

There are many different wall tie types available for use in brick masonry cavity walls. These include unit ties, horizontal joint reinforcement and adjustable ties.

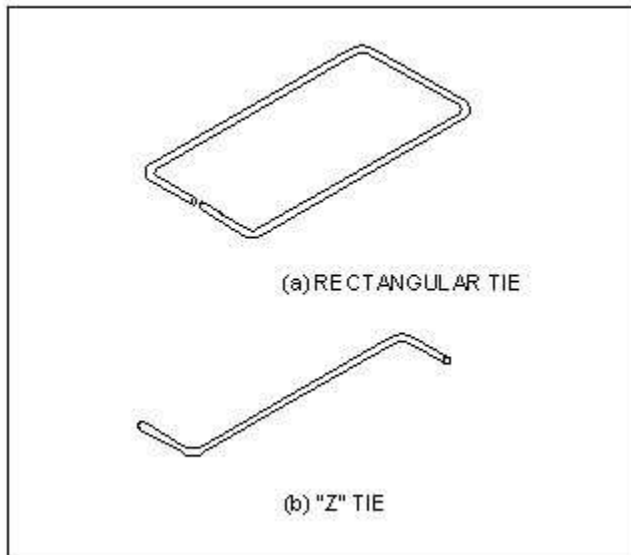

Unit Ties
Fig.1

Unit Ties

Unit ties can be rectangular ties or "Z" ties as shown in Figure 1. These tie types are usually fabricated from cold-drawn steel wire in accordance with ASTM A 82 Specification for Steel Wire, Plain, for Concrete Reinforcement. They can also be fabricated from stainless steel conforming to ASTM A 167 Specification for Stainless and Heat-Resisting Steel Plate, Sheet and Strip for use in more corrosive environments. Corrugated sheet metal ties are not recommended for brick masonry cavity walls because they do not usually transfer loads properly between wythes.

Wall ties with drips should not be used since they reduce the capacity of the ties significantly.

Metal "Z" ties should only be used between wythes of solid masonry units in brick masonry cavity walls. Rectangular ties can be used for all brick masonry cavity walls and are therefore recommended instead. Wire ties should be either wire size W1.7, [No. 9 gage, (0.148 in.) (3.8 mm)] or W2.8, [3/16 in. (4.8 mm)] in diameter.

Horizontal Joint Reinforcement

Continuous horizontal joint reinforcement should meet the requirements of ASTM A 951 Specification for Masonry Joint Reinforcements. Horizontal joint reinforcement is typically produced in 10 to 12 ft (3 to 4 m) lengths. Longitudinal wires are typically W1.7 [No. 9 gage, (0.148 in.) (3.8 mm)] or W2.8 [3/16 in. (4.8 mm)] diameter wire. Cross wires are W1.7 or W2.8 diameter wire and should be spaced at a maximum of 16 in. (400 mm) on center horizontally. Cross wires without drips should be used. The total thickness of the wires should not exceed one-half the joint thickness. Horizontal joint reinforcement configurations available are the ladder, truss and tab types as shown in Fig. 2.

Tests indicate that brick masonry cavity walls tied by the use of horizontal joint reinforcement perform similar to that of the same wall systems tied together with metal unit ties. These tests also indicate that truss-type joint reinforcement used in brick cavity wall construction helped to develop a degree of composite action in the horizontal span, but did not contribute to any composite action in the vertical span. This restraint in the horizontal direction will reduce the amount of in-plane movement and possibly result in bowing of the masonry walls. Thus, truss-type joint reinforcement is not

recommended for brick and block cavity walls.

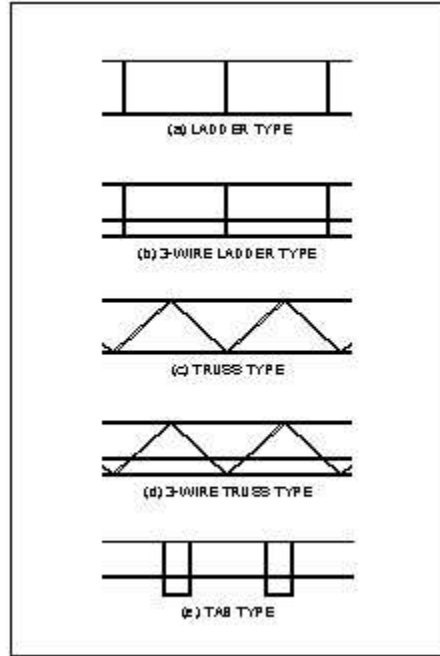

Joint Reinforcement
Fig. 2

Adjustable Ties

Use of adjustable ties has increased for several reasons: 1) the structure can be enclosed faster since the exterior brick wythe can be erected later in the construction process; 2) adjustable ties compensate for the height differences between wythes and construction tolerances; and 3) they can accommodate larger differential movement between wythes.

When specifying adjustable ties, there are certain conditions which must be considered. The model building codes limit the vertical offset between the eye and pintle components to 1 1/4 in. (31.8 mm). Maximum play within the connecting pieces is limited to 3/16 in. (1.6 mm). Once engaged, the pieces should not be able to separate. The strength and stiffness of adjustable ties are generally less than that of unit ties or horizontal joint reinforcement. Thus, more ties are required.

Adjustable Unit Ties. Such ties available for brick masonry cavity walls are shown in Fig. 3. These ties typically have two-pieces consisting of a double eye and pintle configuration. Adjustable unit ties should be at least W2.8 [3/16 in. (4.8 mm)] in diameter and meet the conditions previously stated.

Adjustable Joint Reinforcement Assemblies. Adjustable ties with ladder- and truss- type joint reinforcement are also produced. This type of tie consists of rectangular tie extensions connected to standard joint reinforcement, see Fig. 4.

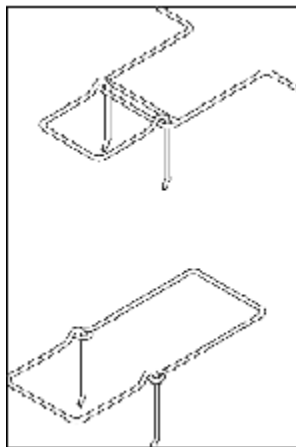

Adjustable Unit Ties
Fig.3

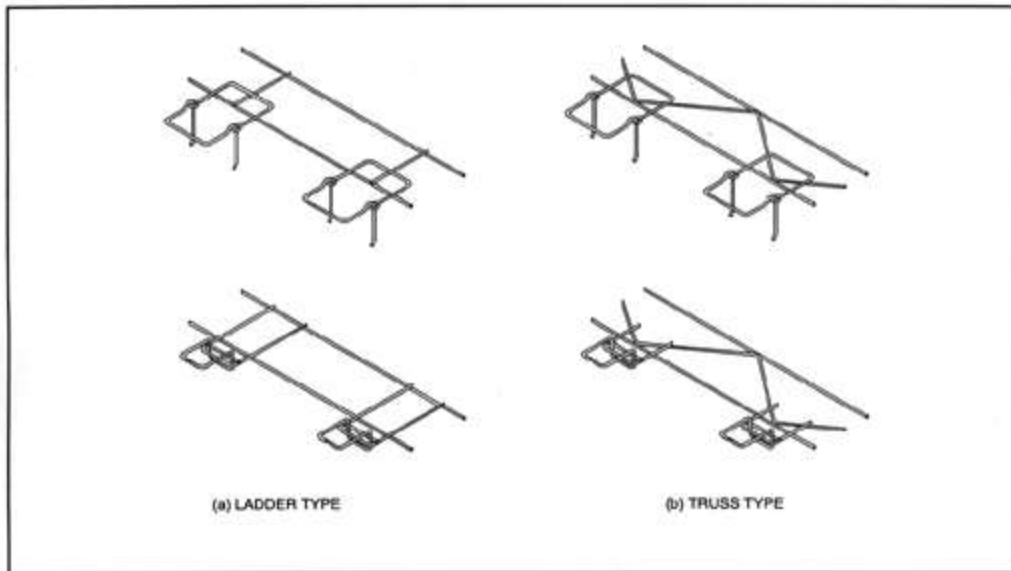

Adjustable Joint Reinforcement
FIG. 4

Corrosion Resistance

Corrosion potential can be affected by the function of the structure, geographic location, presence of insulation or vapor retarders (alters the dew point within the wall), compatibility of construction materials, design and detailing of the wall system and workmanship used in construction. Resistance to corrosion can be provided by control of environmental factors or by selection of the tie material.

There are three types of materials used for corrosion protection of wall ties: galvanizing (zinc coatings), stainless steel and epoxy coatings. Galvanizing provides resistance to corrosion in two ways. First, the zinc coating acts as a barrier to corrosion by shielding the underlying metal. Second, the zinc coating acts as a sacrificial element that is consumed by the corrosive environment before the base metal is attacked. Generally, as the thickness of the zinc coating increases, the period of protection increases.

Two methods of galvanizing are available: mill galvanizing and hot-dip galvanizing. Mill galvanizing takes place after the steel wire has been drawn, but prior to fabrication of the tie. Therefore, the cut end of the tie will not be protected. Hot-dip galvanizing is performed by dipping the completed assembly into molten zinc until a specified amount of zinc is bonded to the base metal. Hot-dip coatings are typically thicker than mill galvanizing, and therefore, provide longer periods of protection. Minimum corrosion protection for galvanized ties should be according to ASTM A 153, Class B-2 (1.5 oz/ft²) (458 g/m²). Zinc coating requirements are related to the size of the element to be coated.

Stainless steel can be used for unit ties or joint reinforcement to resist corrosion. Stainless steel materials should conform to ASTM A 167, Type 304.

Another method recently developed for corrosion protection of metal ties is epoxy coating. The application of an epoxy coating is similar to that for reinforcing bars used in reinforced concrete or masonry construction. Epoxy coatings provide protection by acting as an impervious barrier. These coatings are applied to the base steel by an electrostatic spray method. The coating bonds to the steel by a heat-induced chemical reaction in which chemical and mechanical bonds form. This aids in preventing cracking of the coating due to handling and installation. This coating type is not sacrificial like zinc coatings. At present, an ASTM Standard governing this type of corrosion protection has not been developed. Some manufacturers have been using an adaption of ASTM A 775 Specification for Epoxy-Coated Reinforcing Steel Bars for metal tie purposes. At this time, hot-dip galvanizing is preferred over epoxy-coated ties since any nicks, voids or cuts of the epoxy coating could lead to corrosion of the base steel.

THROUGH-WALL FLASHING

Flashing is a necessary component of the wall assembly to assure the excellent moisture penetration resistance of brick masonry cavity walls. Its main purpose is to collect any moisture that penetrates the exterior wythe and divert it to the outside of the wall system.

There are a variety of flashing materials that can be used with brick masonry cavity walls. Flashing for masonry construction generally fall into three categories: sheet metals, composite materials (combination flashing) and fabrics (plastic or rubber compounds). Materials such as polyethylene sheeting and asphalt-impregnated building felt should not be used as flashing materials. These materials can be easily torn or punctured during installation.

Flashing must possess certain physical properties. Water resistance is the main attribute. However, flashing should also be durable and resistant to damage during installation. Resistance to puncturing or tearing and resistance to

ultraviolet light must be evaluated in flashing selection. Flashing material should not be susceptible to corrosion in fresh mortar or react with adjacent materials such as rigid insulation. Flashing should be easily formed into the desired shape. Compatibility with materials such as sealants or adhesives should be reviewed. Expected life of the flashing materials should be the expected life of the structure, at a minimum. All of these qualities of the flashing material must be taken into consideration in selection because replacement is expensive. Table 2 describes the thickness and advantages and disadvantages of flashing materials that can be installed in brick masonry cavity walls.

TABLE 2
Flashing Materials

Material	Minimum Thickness	Advantages	Disadvantages
Stainless Steel	0.01 in. (0.25 mm)	Extremely durable, non-staining	Difficult to solder and form, high cost
Cold Rolled Copper	10 oz/ft ² (3100 g/m ²)	Extremely durable	May stain adjacent masonry, high cost
Copper Laminates	5 oz/ft ² (1500 g/m ²)	Easy to form, easy to join, non-staining	Some coatings not compatible with adjacent materials
EPDM	30 mils (0.8 mm)	Flexible, easy to form, easy to join, non-staining	Metal drip edge may be required
Rubberized Asphalt	30 mils (0.8 mm)	Self-healing, flexible, easy to form, easy to join, non-staining	Degrades in UV light, dimensional instability, incompatible with sealants, metal drip edge required
PVC	30 mils (0.8 mm)	Flexible, easy to form, easy to join, non-staining, low cost	Questionable durability, easily torn, metal drip edge required
Galvanized Steel	0.015 in. (0.38 mm)	Non-staining	Difficult to solder, subject to early corrosion at bends

Sheet Metals

Sheet metals used for flashing include stainless steel, copper, lead-coated copper and galvanized steel. Aluminum should not be used since it can corrode in fresh mortar. Stainless steel and copper materials are the most durable, but are also the most expensive. Galvanized steel has also been used in limited applications. These flashing materials have a greater life expectancy than composite or fabric flashing. Sheet metal flashing is bent and formed on site and sealed by soldering or with adhesives and rivets. This additional installation time can result in additional construction costs. Stainless steel materials should conform the ASTM A 167 Specification for Stainless and Heat-Resisting Steel Plate, Sheet and Strip. Copper flashing should comply with ASTM B 370 Specification for Copper Sheet and Strip for Building Construction. Solder should conform to ASTM B 32 Specification for Solder Metal.

Composites

Composite or combination flashings are typically less expensive than sheet metal and are easier to install. The most predominant type is a thin layer of metal sandwiched between one or two layers of another material. The metal layer is usually of aluminum, copper or lead. It is covered on one or both sides with various materials, such as asphalt coatings, kraft paper, fiberglass fabric or plastic films. Product literature should be reviewed to determine whether these materials are appropriate for use in brick masonry cavity walls. Consideration should be given to compatibility with adjacent sealants, delamination due to moisture penetration and movement of the wall system.

Plastic and Rubber Compounds

These flashing materials are usually the least expensive flashing suitable for brick masonry cavity walls. They are

flexible and can make complex shapes, except in the heavier thicknesses. Polyvinyl chloride (PVC), Ethylene Propylene Diene Monomer (EPDM) and rubberized asphalt are the most common plastic flashings available. PVC deteriorates and breaks down when exposed to ultraviolet (UV) light. The material also becomes brittle and shrinks over time due to loss of plasticizers. Some PVC flashing is not compatible with polystyrene insulation and can cause the insulation to degrade. However, not all PVC flashings have experienced such problems. Appropriate quality, density and thickness of PVC flashings are paramount to successful performance and should be obtained from well-recognized manufacturers.

EPDM was originally developed as a roofing membrane. However, this type of material has been gaining widespread use as through-wall flashing for masonry walls. It has increased resistance to weathering and performs better in low temperature environments than PVC. EPDM should be in a cured state. Junctures and laps of plastic flashing are usually sealed with plastics or adhesives. These materials may require a metal drip edge adhered to the flashing when exposed to exterior elements. EPDM should be talc free or the talc should be removed where laps are formed. Another type of fabric flashing is a self-adhering, rubberized asphalt. This flashing material easily adheres to itself at junctures, laps and interior wall surfaces and can be self healing to some extent. However, this material cannot be placed on damp, dirty or dusty surfaces. The adhesion properties may be reduced during cold weather. Rubberized asphalt can also degrade in the presence of UV light and therefore, requires the same type of drip edge as other plastic flashing materials.

WEEP HOLES

Weep holes channel moisture collected on the flashing to the exterior of the wall assembly. For best performance, weep holes should always be located directly on the flashing. If weep holes are installed one to two masonry courses above the flashing, they will not perform their intended function. Some types of weep holes may aid in drying out the wall system, although this is not their primary purpose.

Weep holes can be formed in a number of ways. Some of the most common are: 1) omitting mortar in all or part of the head joint; 2) use of removable rods or ropes; 3) plastic or metal tubes; and 4) use of a wicking material. There are also plastic and metal vents that cover weep holes used in lieu of mortar in vertical head joints. Open head joints are recommended as weep holes; however, as long as weep holes remain open for drainage and positioned at the required flashing locations with the appropriate size and spacing, the specific type of weep hole selected is not critical.

DRAINAGE MATERIALS

For brick masonry cavity walls to retard moisture infiltration, the air space separating the masonry wythes must be kept clean of mortar droppings or mortar that may bridge the air space. These obstructions can render flashing and weep holes ineffective.

While it is important to keep cavities clear, there are a number of approaches available to keep open a drainage path to the weep holes. Drainage materials can be installed above flashing consisting of materials configured and installed to allow water to flow around any mortar droppings. The use of these materials does not negate the importance of good workmanship and may not be required in all situations. Use of drainage materials may result in the mortar bridging the air space at certain locations, possibly above the flashing level. This may lead to isolated spots of dampness on the interior or exterior wythe. At worst, it could lead to a path for water penetration. In all cases, the cavity size should be maintained.

A layer of pea gravel with an approximate diameter of 3/8 in. (10 mm) can be placed on top of flashing installations within the wall system. This layer should be approximately 2 to 3 in. (50 to 75 mm) deep. This will help to keep mortar droppings from clogging weep holes. The smallest gravel size should be larger than the weep hole opening so as not to interfere with drainage. It is recommended that a bed of mortar, conforming to the curve of the flashing, be placed under the flashing for additional support of the pea gravel. Care must be exercised when installing pea gravel at bolted shelf angle locations. The weight of the gravel on the flashing may cause tearing or puncturing at the bolt head. Pea gravel at loose lintels needs to be contained so it does not flow off the end. Fig. 5 shows a typical detail for the use of pea gravel although it would apply to many of the drainage materials.

Mesh materials are gaining popularity. These materials are usually manufactured from high density polyethylene or nylon strand and are available in 1 in. to 2 in. (25 mm to 50 mm) thicknesses. They keep weep holes open and permanently suspend the mortar above the flashing level. Many have unique patterns such as dovetail shapes which break up mortar droppings so moisture has open flow paths to flashing and weep holes.

Another mortar dropping control device consists of staggered shelves inserted in the cavity such that they overlap each other. The individual pieces are fixed in place by tabs which are mortared into the outer wythe of masonry. This may collect mortar droppings above the flashing level and create a bridge for moisture to cross the cavity.

Some manufacturers of rigid board insulation provide a grooved face with an adhered filter fabric that is positioned in the air space towards the exterior. The aligned grooves act as a channel which allow moisture to drain down to the flashing and weep holes in the wall system. The grooves are intended to provide drainage capabilities in the event of the air space being clogged during construction of the masonry wythes; however, the grooves must align vertically for proper drainage. Other rigid insulation boards have an adhered mesh material which behaves in a similar manner.

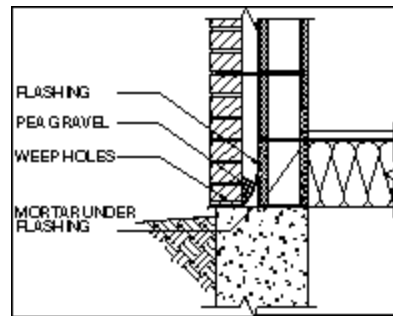

EXPANSION JOINT MATERIALS

Building materials and elements used in construction react differently to loading and environmental conditions. Thus, they are constantly moving. A system of movement joints is necessary to accommodate these expected movements. For wythes of brick masonry, placement of expansion joints is necessary to permit these movements without concern. Typical expansion joint details are shown in Fig. 6. A backer rod and sealant must always be installed to resist moisture penetration at the expansion joint location. A filler material may be used in the expansion joint behind the backer rod to keep debris out of the joint during construction. Common expansion joint filler materials are pre-molded foam pads and neoprene pads. The sealant, backer rod and filler material, if present, must be designed to allow the expected movement; therefore, the movement potential of these materials must be included when determining expansion joint size and spacing. Expansion joint fillers should conform to ASTM D 1056 Specification for Flexible Cellular Materials - Sponge or Expanded Rubber, Class 2A1.

Sealants come in many varieties and usually consist of polyurethanes, polysulfides or silicone. Sealants which exhibit the highest movement capabilities should be specified. Sealants should conform to ASTM C 920 Specification for Elastomeric Joint Sealants. For adequate sealing of expansion joints the sealant must bond well to the adjacent brickwork, flashing, windows, etc. Sealant manufacturers should be consulted to determine whether priming is necessary based on the sealant material selected. Oil-based caulking compounds should not be used as sealants for masonry wall assemblies because most lack the necessary flexibility and durability needed for in-service use. Backer rods are used to keep the sealant at the appropriate depth, provide a suitable shape for the sealant and act as a bond breaker to prevent back-adhesion. The backer rod should be slightly larger than the joint. Closed cell polyethylene rods are recommended and should be free from punctures.

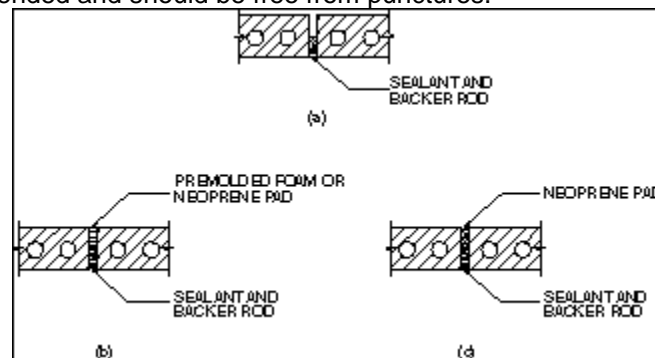

STEEL SHELF ANGLES AND LINTELS

Several different types of steel members can support either the exterior or interior wythe of a brick masonry cavity wall. They generally fall into two categories: shelf angles and lintels. Shelf angles are used in panel wall systems to support the exterior wythe of brick masonry at floor levels. Shelf angles are anchored to floor slabs or beams and break the exterior wall facade into sections. Loose angle lintels are generally used over wall openings to support the masonry above. Typical loose angle lintels bear on the masonry at each end of the opening and are not attached to the frame or backing.

Steel for shelf angles and lintels should conform to ASTM A 36 Specification for Carbon Structural Steel. Steel angles should be at least 1 $\frac{1}{4}$ in. (6 mm) thick with a horizontal leg of at least 3 $\frac{1}{2}$ in. (89 mm) for use with nominal 4 in. (100 mm) brick wythes and 3 in. (75 mm) for use with nominal 3 in. (75 mm) thick brick wythes. Further information on the design of steel lintels can be found in Technical Notes 31B Revised.

The use of galvanized steel shelf angles or lintels may be necessary in areas subject to severe corrosion. Steel lintels, if not galvanized, should be painted before installation. These steel members support the weight of the masonry and must remain in good condition. Repair or replacement of shelf angles or lintels is time consuming and costly so the selection of adequate materials is critical to long service life.

INSULATION MATERIALS

In cavity wall construction, the prescribed air space acts as an insulating layer in addition to the masonry units. Thermal performance of the system can be further enhanced by placing insulation materials in the cavity. Insulation materials used in brick masonry cavity walls include inorganic cellular materials such as perlite and vermiculite, and organic cellular materials such as polystyrene, polyurethane, polyisocyanurate and foams. These insulation types are manufactured in the form of rigid boards, granular fills and foams. Each of these types, if properly used, will result in a more thermally efficient wall system.

Although the most important characteristic for insulation is its thermal resistance, other properties should be considered including water absorption, combustibility, density, insect resistance and ease of installation. The following criteria can be used for the selection of insulation materials for brick masonry cavity walls:

1. The insulation must permit the air space to perform its function as a barrier to moisture penetration by allowing moisture to drain without passage to the interior wythe.
2. Thermal insulating efficiency must not be impaired nor degrade over time due to retained moisture from any source, i.e., wind-driven rain or vapor condensation.
3. Insulating materials must be long lasting, resisting rot due to moisture or dryness, offering no food value to vermin and meeting the building code requirements for flame resistance.
4. Granular fill materials must be capable of supporting their own weight without settlement to assure that no portion of the wall is without insulation and allow moisture to drain from the cavity.
5. Foam insulation materials must not shrink with age to assure that no portion of the wall is without insulation and that moisture does not have a path to migrate to the interior wythe.
6. Rigid boards must be firmly attached to the backing so as not to become dislodged in the cavity and allow air or water movement around the insulation.
7. Consider environmental concerns regarding off gassing and recycling of insulation materials.

Properties of insulation materials vary widely. Table 3 shows various properties of insulation materials used in brick masonry cavity walls. The thermal conductivity (k) and thermal resistance (R) provide a means of comparing the insulating properties of insulation materials. These are determined in accordance with ASTM C 177 Test Method for Steady-State Heat Flux Measurements and Thermal Transmission Properties by Means of the Guarded-Hot-Plate Apparatus measured at various temperatures. Due to the large number of types of insulation, and even larger number of manufacturers, Table 3 lists only a few representative values of physical properties. For some materials, an aged or stabilized value is given. In all cases, the aged or stabilized value is the one that should be used in design. Individual manufacturers should be consulted for design values and other properties of their specific materials and their applications.

TABLE 3
Insulation Material Properties¹

Material	Density, lb/ft ³ (kg/m ³)	Thermal Conductivity (k), BTU • in./hr • ft ² • °F	Thermal Resistance (R), per inch, °F • ft ² • hr/BTU • in.	Permeance, Perms ²
Granular Fills				
Vermiculite	4.0 - 6.0 (64 - 96)	0.44	2.27	n/a
Perlite	2.0 - 11.0 (32 - 176)	0.27 - 0.42	2.4 - 3.7	n/a
Rigid Boards				
Extruded Polystyrene	1.8 - 3.5 (29 - 56)	0.20	5.0	0.83
Expanded Polystyrene	1.0 - 2.0 (16 - 32)	0.23 - 0.26	3.85 - 4.35	0.50 - 0.17
Polyisocyanurate (with facers)	2.0 (32)	0.14	7.04	n/a
Foamed-in-place				
Polyurethane	1.5 - 2.5	0.16 - 0.18	6.25 - 5.56	n/a
Polycyrene	n/a	0.25	4	n/a
Foamed Minerals	2.25 (36)	0.26	3.9	n/a
Amino-plast	0.8 (13)	0.20	4.9	n/a

¹(hr • °F • ft²) / BTU • in. = 6.933 (m • K)/W

²(in. • Hg ft² • hr/gr)/in. = 1.459 x 10⁻¹² kg/(Pa • s • m)

Rigid Boards

There are many rigid board insulation materials that can be installed in the air space of brick masonry cavity walls. Among the most common are: expanded and molded polystyrene, extruded polystyrene, expanded polyurethane, polyisocyanurate, mineral fibers and perlite board.

Composition. Rigid board insulations are many and varied. They include the various mineral fiber boards and cellular insulation including polystyrenes, polyurethanes and polyisocyanurates. Air, or other gases, introduced into the material expands the material by as much as 40 times. Cells are formed in various patterns—open (interconnected) or closed (unconnected). Most rigid insulation is expanded with hydrogenated chlorofluorocarbons (HCFC), pentane or other hydrogenated gases used as blowing agents. Gradual air leakage into the cells may replace some of the original gas and eventually reduce the thermal insulating quality. Some types of insulation use foil facers. These facers keep air leakage to a minimum and must not be punctured during construction. Aged R-values should be used when comparing different types of insulation.

Fibrous insulation materials include wood, cane, or vegetable fibers bonded with plastic binders. To make them moisture resistant, they are sometimes impregnated with asphalt. Fibrous glass insulation consists of a core board of non-absorbent fibers held together by phenolic binders and a surface coating of asphalt-saturated organic material reinforced with glass-fiber.

Properties. Water entrapped in insulation can destroy its thermal insulating value. Water vapor can flow wherever air can flow—between fibers, through interconnected open cells, or where a closed cell structure breaks down. Wherever water replaces air, the insulating value drops drastically since water's thermal conductivity exceeds that of air by 20 times.

Fibrous organic insulations are especially vulnerable to moisture damage. Free water will eventually damage any fibrous organic material or organic binder. Fiberboard exposed to moisture for long periods of time may warp or buckle and eventually decay. The expansion and contraction that accompanies the changing moisture content may lead to problems.

Though less vulnerable to moisture, inorganic materials are not immune. Water penetrating into fiberglass insulation not only impairs the insulating value, but may also dissolve the binder. Some types of cellular insulation may also break down under repeated freeze/thaw cycles.

Rigid board insulation should conform to one of the following: ASTM C 208 Specification for Cellulosic Fiber Insulating Board, ASTM C 552 Specification for Cellular Glass Thermal Insulation, ASTM C 578 Specification for Rigid, Cellular Polystyrene Thermal Insulation, ASTM C 1224 Specification for Reflective Insulation for Building Applications, ASTM C 1289 Specification for Faced Rigid Cellular Polyisocyanurate Thermal Insulation Board, ASTM D 3490 Specification for Flexible Cellular Materials - Bonded Urethane Foam and ASTM D 3770 Specification for Flexible Cellular Materials - High Resilience Polyurethane Foam. There may be other products available for rigid foam products; therefore, manufacturer's literature should be reviewed before selection.

Granular Fills

Granular fills are typically used in the hollow cells of concrete block backing. However, they can be used in the cavity. One advantage of granular fills is that they can be installed after wall sections have been completed. This permits the mason to work uninterrupted thus shortening construction time and lowering costs. However, the water resistance of the fill is of utmost importance. Settling of the fill material could lead to thermal bridging in the wall system.

Two types of granular fill insulation have been found to meet the objectives of cavity wall insulation. These are water-repellent vermiculite and silicone-treated perlite insulation.

Vermiculite is an inert, lightweight, granular insulating material manufactured by expanding an aluminum magnesium silicate mineral, which is a form of mica. The raw material is made up of approximately one million separate layers per inch, with a minute amount of water between each layer. When particles of the mineral are suddenly exposed to temperatures in the range of 1800°F to 2000°F (982°C to 1093°C), the water changes to steam, causing the vermiculite to expand into cellular granules of vermiculite insulation about 15 times their original size.

Perlite is a white, inert, lightweight, granular insulation material made from volcanic siliceous rock. When the crushed stone is heated to approximately 1800°F (982°C), it expands or pops much like popcorn as the combined water vaporizes and creates countless, tiny bubbles in the heat-softened, glassy particles. Perlite can be expanded up to 20 times its original volume.

Water-repellent vermiculite and silicone-treated perlite should conform to ASTM C 516 Specification for Vermiculite Loose Fill Thermal Insulation and C 549 Specification for Perlite Loose Fill Insulation, respectively. Each of these specifications contains limits on density, grading, thermal conductivity and water repellency. Some properties of these materials is given in Table 3.

Foamed-in-place Insulation

Foamed-in-place insulations have traditionally been used to fill the cells of hollow masonry units. However, new technology has now produced foamed-in-place insulations that can completely fill the air space between the two wythes of a brick masonry cavity wall. One advantage of these foamed-in-place insulations is that they can be

installed after wall sections have been completed. However, the water resistance of brick cavity walls with these types of insulation materials are unproven in the field. Shrinkage of the foam material could lead to moisture drainage paths through the wall system. In addition, mortar bridging in the cavity may not allow the foam to flow around it properly. These materials used in the cavity contradict the drainage system and should be considered a barrier wall system. Most foams are a two component system. They are formed by a chemical reaction of two liquids. They are placed under pressure, so newly constructed walls must be cured long enough to resist the pressures. Typical compositions of these foams are urethane, polyisocyanate, magnesium oxychloride cement and ceramic talc and amino-plast resin. Since most of these products are proprietary, there are no ASTM standards at this time to verify quality. Therefore, manufacturers literature should be consulted for technical information on applications and usage.

AIR AND VAPOR RETARDERS

Sheets or layers of materials which effectively retard or reduce the flow of air and water vapor are called air retarders and vapor retarders, respectively. In recent years, there has been much confusion pertaining to the functions of each within a masonry wall system. Air retarders limit the amount of air flow through the wall system. Vapor retarders are intended to control transmission of water vapor through building assemblies. A vapor retarder can also serve as an air retarder. An air retarder may or may not serve as a vapor retarder. It is sometimes difficult to ensure that either retarder performs only one function. For example, polyethylene films will function as a vapor retarder, but it will also resist the passage of air.

To provide effective air and vapor retarders, it is necessary to seal joints in these materials so that continuity is provided. It is also necessary to seal around the edges of wall openings such as windows, doors and access for utility services. Adhering or taping of the joints should be specified. The adhesive or tape used must be compatible with the material composition of the retarder in addition to performing adequately when exposed to moisture.

Air Retarders

Masonry cavity walls can appear to be relatively air tight, but may experience high air leakage rates. Parging the exterior or interior face of the interior masonry wythe with mortar is one method to reduce air leakage, but it will crack if the wythe cracks. Membranes or liquid-applied materials usually provide superior performance. Special attention must be given to adjacent materials or structural members intersecting the interior wythe and the membrane. Permanent fixtures in the interior wythe and movement joints at the top and sides of the wythe must provide a continuous air seal to perform successfully.

For improved air retarder performance, the air and vapor retarders can be included in combination with mortar parging. The parging provides a base for the application of the vapor retarder. The vapor retarder must be able to span possible movement cracks in the interior wythe.

Interior or exterior insulation boards applied to the interior wythe can also form part of the air retarder system. For insulation to work effectively as a retarder, proper adhesion to the interior wythe by the use of full grid of adhesive will eliminate air spaces between the insulation and the interior wythe. Mechanical anchorage may provide a tight fit of the insulation to the interior wythe. Joints between insulation boards must be sealed with a moisture resistant tape or sealant.

Interior gypsum board finish materials can be used as air retarders when joints are properly sealed. Even when the interior wall covering is not intended to serve as the main air retarder, it is suggested that steps be taken to provide good air tightness in order to reduce possible air circulation in air spaces in the interior wythe.

Vapor Retarders

There are many materials that can be used to effectively provide vapor transmission resistance. However, the installation methods vary just as much as the materials themselves. Selection should consider the material and ease of application for the best results.

The vapor retarder selection depends on the type and location of insulation in the brick masonry cavity wall and the interior and exterior climate. While some materials and methods of application may be successful in the cavity or on the interior side of the interior wythe, there are certain vapor retarders which perform better on one side than the other. Suitable vapor retarders consist of two coats of oil-based or alkyd emulsion paint on the interior side of the wall finish; a 15-mil thick polyethylene sheet over the insulation; or the insulation itself if it is highly impermeable to water vapor transmission and has taped or sealed joints. Foil-faced insulation and extruded polystyrene insulation boards meet these criteria.

When the vapor retarder is installed within the cavity space, other material options are available. Paints or suitable coatings can be applied to the outside face of the interior wythe, but must have the ability to span or bridge small cracks. The vapor retarder can also consist of torched-on or spray-applied bituminous coatings, self-adhesive plastic sheets or plastic materials.

The material must be continuous and be able to accommodate possible movement cracks that may form in the masonry. For long term performance, vapor retarder materials must remain firmly affixed as vapor pressure

differentials occur. These materials must be chemically compatible with any insulation placed in the cavity. If the insulation is used as the vapor retarder, it must be held firmly in place by adhesives or mechanical anchorage. In addition, the joints between the insulation boards must be fully sealed with moisture resistant sealant or tape.

SUMMARY

This Technical Notes is the second in a series dealing with brick masonry cavity walls. It is concerned primarily with recommended properties and selection of materials. Other Technical Notes in this series discuss cavity walls in general, design, detailing and construction.

The information and suggestions contained in this Technical Notes are based on the available data and the experience of the engineering staff of the Brick Industry Association. The information contained herein must be used in conjunction with good technical judgment and a basic understanding of the properties of brick masonry. Final decisions on the use of the information contained in this Technical Notes are not within the purview of the Brick Industry Association and must rest with the project architect, engineer and owner.

REFERENCES

- 1."Brick Masonry Cavity Walls," Technical Notes 21 Revised, Brick Industry Association, Reston, VA, August 1998.
- 2.Handbook of Fundamentals, American Society of Heating, Refrigeration and Air Conditioning Engineers, Inc., Atlanta, GA, 1997 Edition.
- 3."Thermal Insulation, Environmental Acoustics," Volume 04.06, Annual Book of ASTM Standards, American Society for Testing and Materials, West Conshohocken, PA, November 1998.
- 4."Through-Wall Flashing," Engineering and Research Digest, Brick Industry Association, Reston, VA, 1996.
- 5."Wall Ties for Brick Masonry," Technical Notes 44B, Brick Industry Association, Reissued Sept. 1988.
- 6."Water Resistance of Brick Masonry, Design and Detailing - Part I of III," Technical Notes 7 Revised, Brick Industry Association, Reston, VA, Reissued Feb. 1998.
- 7."Water Resistance of Brick Masonry, Materials - Part II of III," Technical Notes 7A Revised, Brick Industry Association, Reston, VA, Reissued Dec. 1995.